

**BAHCO®**

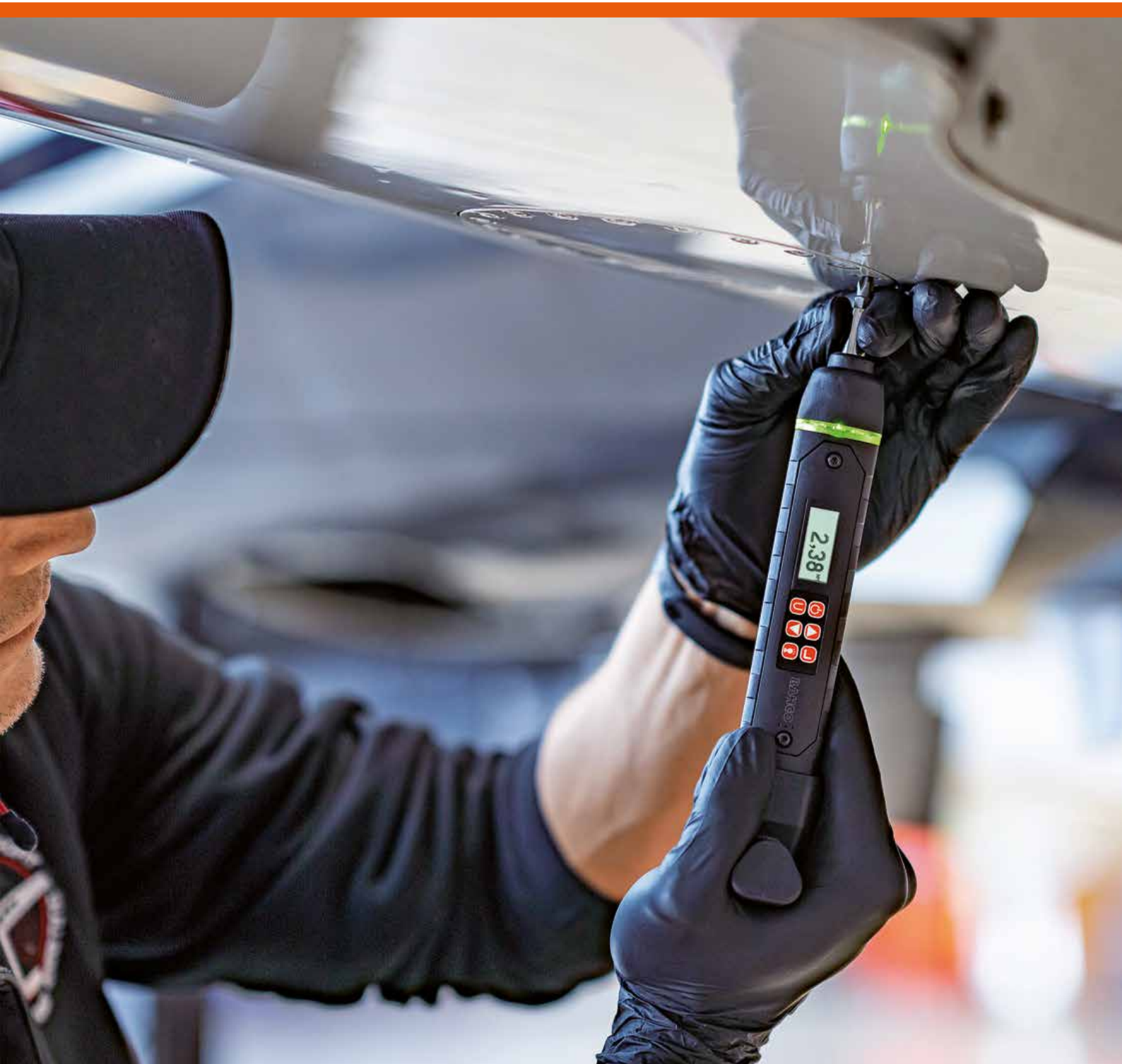

**Torque Solutions**

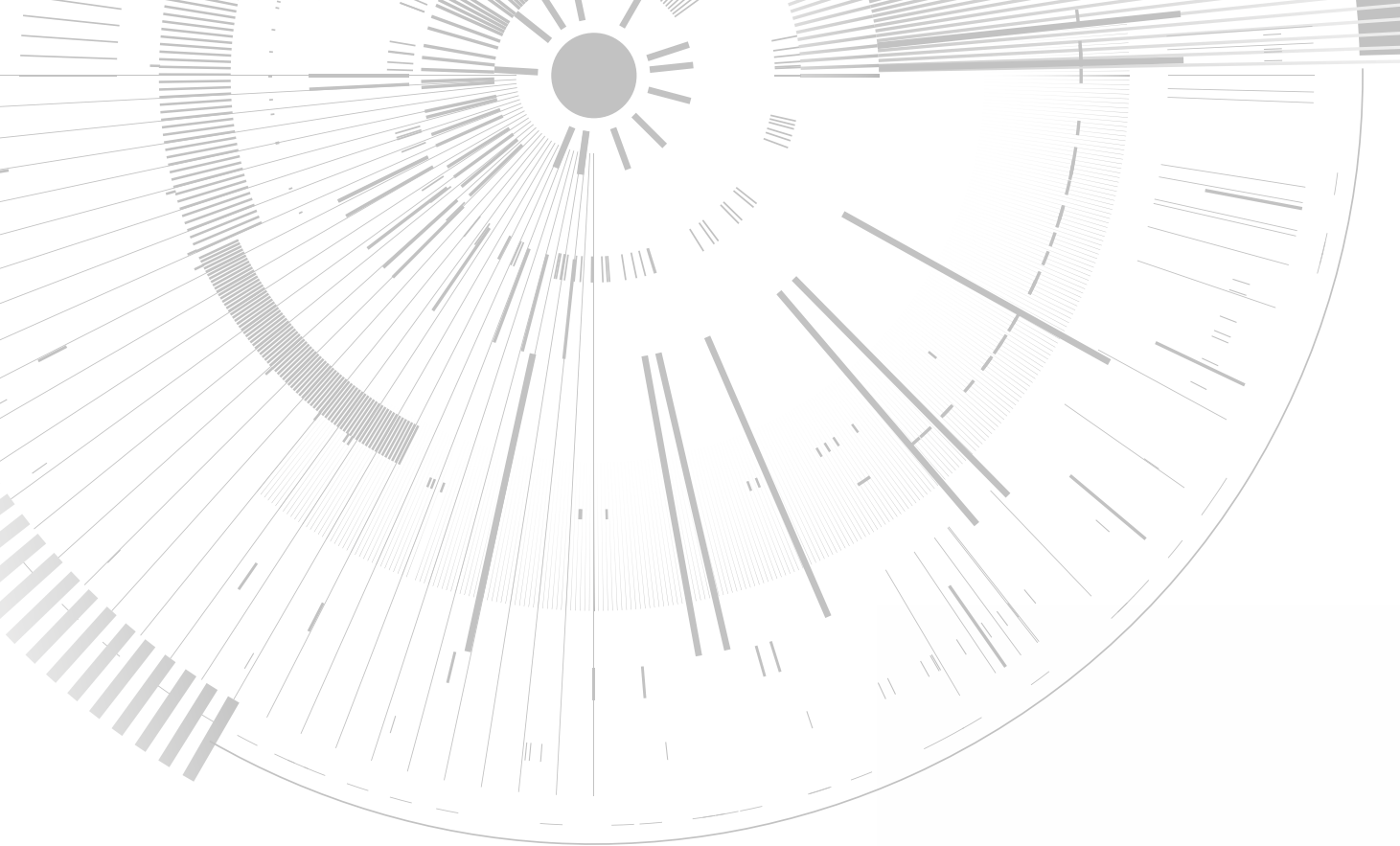



As innovators for over 165 years, we have introduced some of the most advanced tools in the world, and sell through distributors with whom we build long-term partnerships. Bahco products are generally manufactured in our own factories located across Europe and offered by our partner distributors to professionals. This is simply what we do, providing the best quality tools to our partners.

Our many years of knowledge and experience have led to a new range of torque solutions.

## ***A COMPLETE RANGE TO COVER ALL THE NEEDS IN MOST APPLICATIONS***

Bahco offers you one of the largest selections of torque tools available, providing the durability, reliability and accuracy you need to turn and tighten fasteners to the right specification. With Bahco, you get total control.





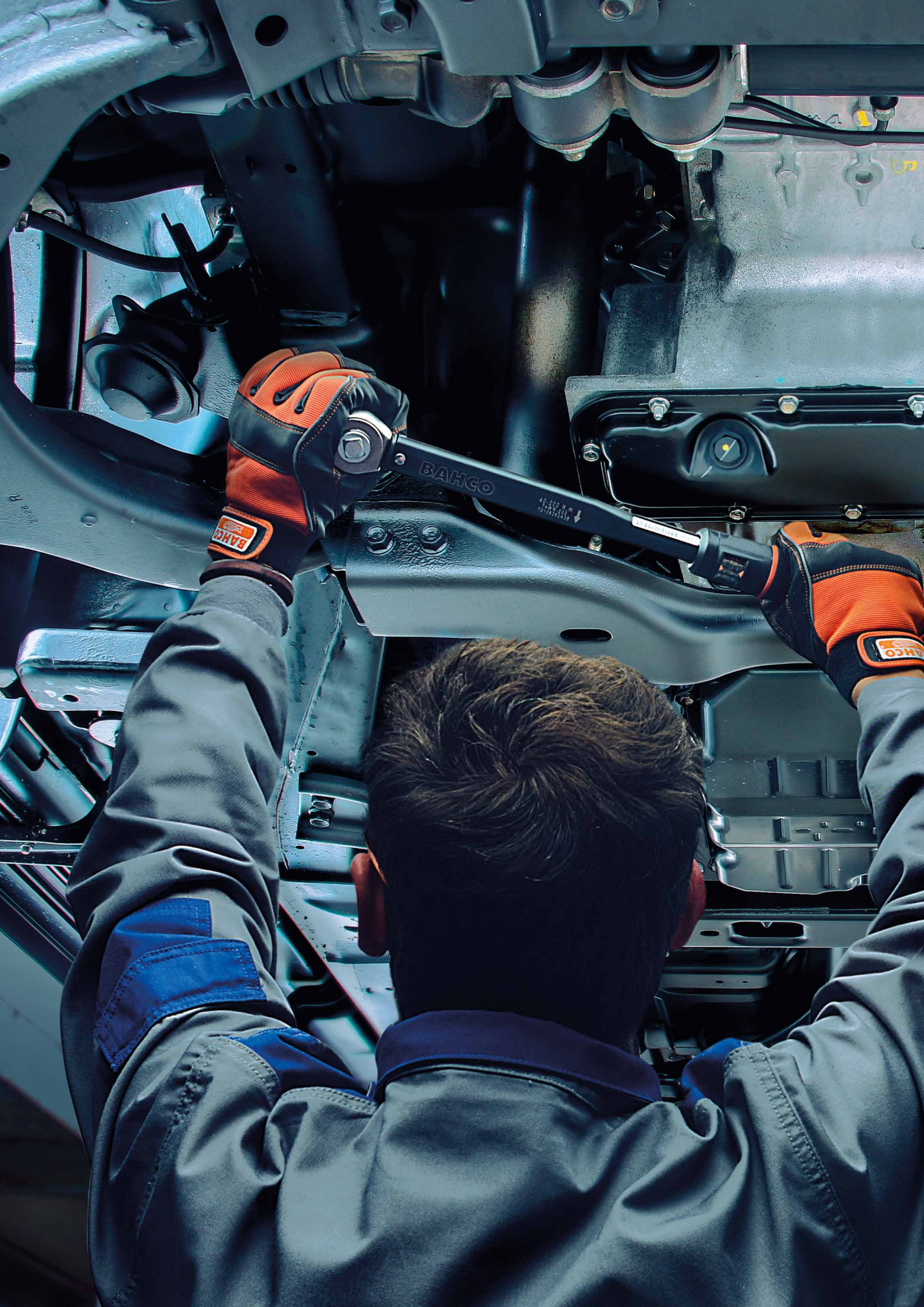

# INDEX

<b>DIGITAL TORQUE WRENCHES</b>	Torque Angle With Bluetooth® Slim .....	11
	Torque Angle With Bluetooth® .....	12
	Torque Angle with USB Slim .....	13
	Torque Angle with USB .....	16
	Torque Angle Slim .....	18
	Torque Angle .....	21
	Torque .....	23

---

<b>MECHANICAL TORQUE WRENCHES</b>	Adjustable Window Click Wrenches .....	26
	Adjustable Free-Hand Point Click Wrenches .....	29
	Adjustable Marked Scale Click Wrenches .....	32
	Torque Tools at Height .....	37
	Non Sparking Torque Tools .....	39
	Adjustable Window Breaking Wrenches .....	41
	Dial Wrenches .....	44
Preset Click Wrenches .....	47	

---

<b>DIGITAL AND MECHANICAL TORQUE SCREWDRIVERS</b>	Bluetooth® Torque Angle Screwdrivers .....	52
	USB Torque Angle Screwdrivers .....	54
	Digital Torque Angle Screwdrivers .....	56
	Adjustable Screwdrivers with Scale .....	58
	Preset Screwdrivers .....	62
	Fixed Preset Screwdrivers .....	65
Fixed Preset Screwdriver Blades .....	67	

---

<b>MULTIPLIERS</b>	Hand Torque Multipliers .....	70
--------------------	-------------------------------	----

---

<b>TORQUE TESTERS</b>	Multifunctional Testers .....	76
	Joint Simulators .....	77

---















































<b>TORQUE ANGLE ADAPTORS</b>	Digital Torque & Angle Adaptor .....	82
	Digital Angle Meter .....	83
	Angle Meter .....	84

---

<b>INSERT TOOLS</b>	Rectangular Connector Ratchet & Fixed Square Drive .....	89
	Rectangular Connector Wrenches .....	93
	Rectangular Connector Adaptor .....	97
	Round Spigot Connector Ratchet .....	98

# OVERVIEW Torque TOOLS

## General attributes

Page	Product	Accuracy	Direction	Angle	Drive	Ratchet	Scale	Type	Signal	
12	TAWMB930M/TAWMB24800	±2%*	2	x	9x12-24x32		-	Multiple	Digital	A - S - V
14,16	TAWM912M/TAWM24800	±2%*	2	x	9x12-24x32		-	Multiple	Digital	A - S - V
15,17	TAWM1412M/TAWM34800	±2%*	2	x	1/4"-3/4"		P	Multiple	Digital	A - S - V
19,21	TAW912M/TAW24800	±2%*	2	x	9x12-24x32		-	Multiple	Digital	A - S - V
20,22	TAW1412M/TAW34800	±2%*	2	x	1/4"-3/4"		P	Multiple	Digital	A - S - V
23	IZO-D	±2%	2	-	9x12-14x18		R	Multiple	Digital	A - S - V
23	IZO-DR	±2%	2	-	3/4"		P	Multiple	Digital	A - S - V
27	74WR-15/74WR-25	±3%	1	-	1/4"		R	Dual	Click	A - S
27	74WR-50/74WR-400	±3%	2	-	3/8"-3/4"		T	Dual	Click	A - S
28	74WS	±3%	2	-	16 mm		-	Dual	Click	A - S
28	74W9/74W14	±3%	2	-	9x12-14x18		-	Dual	Click	A - S
30	75R	±3%	2	-	3/4"-1"		T	Dual	Click	A - S
31	75S-650	±3%	2	-	22 mm		-	Dual	Click	A - S
33	7455	±4%	2	-	1/4"-1"		P	Dual	Click	A - S
34	7455-2500	±4%	1	-	1"		-	Dual	Click	A - S
35	7465	±4%	2	-	9x12-27x36		-	Dual	Click	A - S
36	7456-80LB	±4%	1	-	3/8"		P	Single	Click	A - S
38	TAH73R	±3%	2	-	1/2"		R	Dual	Click	A - S
38	TAH74W9	±3%	2	-	9x12		-	Dual	Click	A - S
40	NS041	±6%	1	-	1/4"-1"		P	Dual	Click	A - S
40	NSB041	±6%	1	-	1/4"-1"		P	Dual	Click	A - S
42	76R	±4%	2	-	3/4" - 1"		T	Dual	Break	A - S - V
45	7454	±4%	2	-	1/4"-1"		-	Dual	Dial	A - V
48	74PR-20	±3%	1	-	1/4"		R	-	Click	A - S
48	74PR-60/74PR-400	±3%	2	-	3/8"-3/4"		T	-	Click	A - S
49	74P9/74P14	±3%	2	-	9x12-14x18		-	-	Click	A - S
53	TASMB14H	±2%*	2	x	1/4"		-	Multiple	Digital	A - S - V
55	TASM14H	±2%*	2	x	1/4"		-	Multiple	Digital	A - S - V
57	TAS14	±2%*	2	x	1/4"	 	-	Multiple	Digital	A - S - V
59	6973N/6978N	±6%	1	-	1/4"	 	-	Single	Slip	A - S
59	MA500	±6%	1	-	1/4"	 	-	Single	Slip	A - S
60	TSS120/TSS600	±6%	1	-	1/4"		-	Single	Slip	A - S
61	6852-5	±6%	2	-	1/4"	 	-	Single	Click	A - S
62	6873N/6880N	±6%	1	-	1/4"	 	-	-	Slip	A - S
62	PS501	±6%	1	-	1/4"	 	-	-	Slip	A - S
63	6852P-5	±6%	2	-	1/4"	 	-	-	Click	A - S
66	BE-6990-IP	±10%	1	-	T/IP6-T/IP15		-	-	Slip	A - S
77	TEA003-TEA030	±1%	1	-	1/4"-10 mm		-	Multiple	Digital	A - V
78	TEA065-TEA2100	±1%	1	-	3/8"-1"		-	Multiple	Digital	A - V
83	TAM	±4%	2	x	1/4"-1/2"		-	Multiple	Digital	A - V

Product photo	Special features	Torque range
		1.5-800 N·m
		0.6-800 N·m
		0.6-800 N·m
	-	0.6-800 N·m
	-	0.6-800 N·m
	-	3-340 N·m
	-	81-810 N·m
	-	3-25 N·m
	-	10-400 N·m
	-	3-300 N·m
	-	3-400 N·m
		4-400 N·m
		130-650 N·m
	-	1-1,500 N·m
	-	500-2,500 N·m
	-	1-1,500 N·m
	-	22-108 N·m
		20-300 N·m
		20-100 N·m
	Al-Br	5-900 N·m
	Cu-Be	5-900 N·m
	-	120-2,000 N·m
	-	0.7-1360 N·m
	-	5-20 N·m
	-	4-20 N·m
	-	4-300 N·m
		0.04-9 N·m
		0.04-9 N·m
	-	0.45-9 N·m
	-	0.1-4.5 N·m
		0.1-4.5 N·m
	-	0.2-6 N·m
		1-5 N·m
	-	0.10-4.5 N·m
		0.04-4.5 N·m
		1-5 N·m
	-	0.6-3 N·m
		0.1-30 N·m
		3-2100 N·m
	-	1.5-340 N·m

#### Turn direction:



(1) Clockwise



(2) Anticlockwise

#### Ratchet types:



(P) Pear head



(R) Round head



(T) Push-through

#### Signal type:



(A) Audible signal



(S) Sensitive tactile signal



(V) Visible signal

#### Additional features:



USB data transfer



ESD safe



Non-length-dependent



Bluetooth



Bahco Connect



Drops



BAM

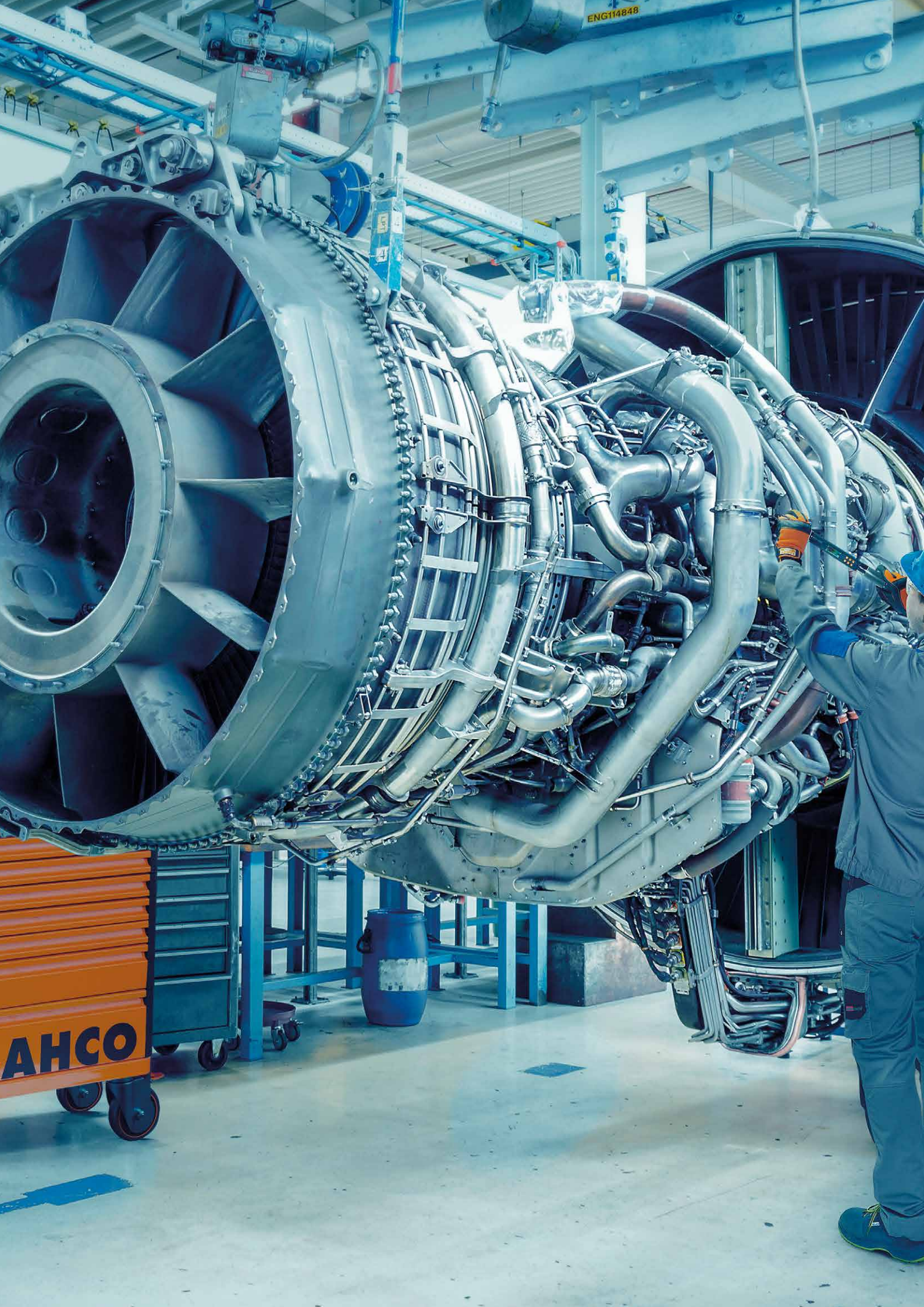

ENG114848

AHCO



Bahco's digital torque wrenches are ideal for the highest requirements, such as accuracy, precision, speed of use, data record and transfer and no over-torque. One digital torque wrench does the job of multiple torque wrenches. They are easy to use, easy to set and easy to recalibrate.

Users of a mechanical torque wrench will immediately understand the benefits of using digital torque wrenches. In addition, production line managers, quality control technicians and laboratory calibration technicians will benefit from using the digital torque wrench to improve productivity, traceability, facilitate calibration and for better control.

Torque-Angle Wrenches are used to apply torque to applications which are specified predominantly for cylinder head bolts but also for main bearing caps and suspension components. As well as measuring torque, these wrenches also measure the angle of rotation in a programmed sequence.

Additionally, for working in low light settings such as at night or in a dimly lit car workshop, you may find that a backlit display is hugely beneficial.

# ***DIGITAL TORQUE WRENCHES***

- *Torque Angle with Bluetooth® Slim*
- *Torque Angle with Bluetooth®*
- *Torque Angle with USB Slim*
- *Torque Angle with USB*
- *Torque Angle Slim*
- *Torque Angle*
- *Torque*



# BAHCO CONNECT

APP FOR BLUETOOTH TORQUE TOOLS



Available free at the different stores

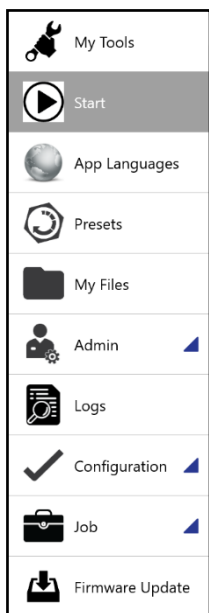
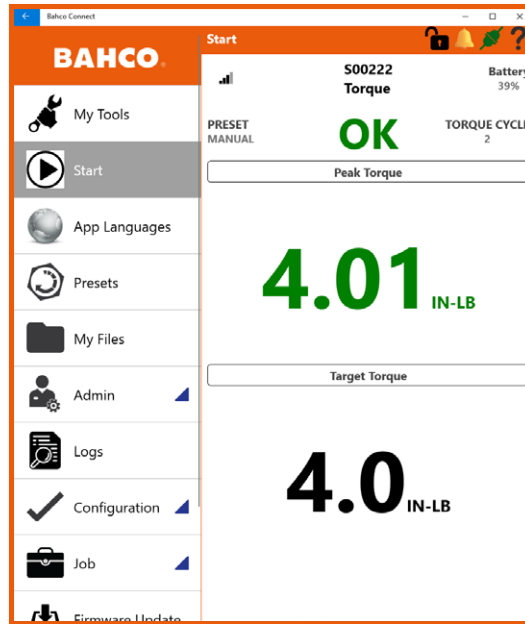
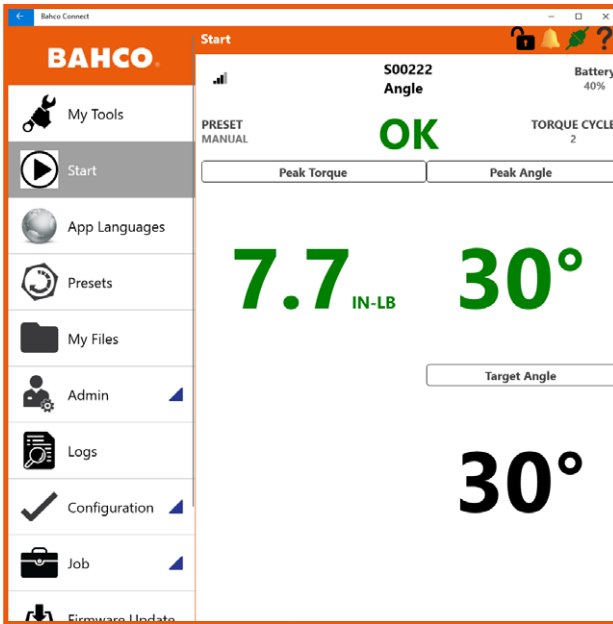

- 20 different languages
- Torque, Angle, Torque then angle, Torque and angle, Prevailing Torque
- Endless libraries of presets
- User profiles
- Torque and angle records with related traceable information
- Traceability field creation, ReDo comments, Recalibration warnings
- Job files (Sequences of presets at a certain order), QR code generator
- Tool firmware update to make the tool evolve along with the app

## MAIN FEATURES AND BENEFITS

- User friendly interface between user and torque tool. You only use the tool to fasten.
- Up to 5 traceability fields to allow you tracking and recording all relevant info for the job at hand
- Win time by feeding the app with traceable information related to a job through QR codes
- Logs (Torque/angle events) along with all the info you want to track will be available at the app and can be saved at your device, shared or e-mailed on a .csv file at any time.
- Preset libraries and Job files can also be saved, shared or e-mailed.
- Recalibration warnings can be configured by time and/or cycle number

# BLUETOOTH® TORQUE ANGLE SLIM WRENCH

*Bluetooth® Digital Torque Angle Slim Wrench with Interchangeable Head*



9x12, 14x18 and 24x32 interchangeable head sizes

Bluetooth® real time 2-way connectivity to a tablet or PC



Free BAHCO CONNECT app available at the different stores for iOS Android and Microsoft

Buzzer.

Fine adjustment. Preset keyboard lock. Faster start-up time.

Vibrating handle. No winding required. All metal construction. Reverse thread end cap.

Dual progressive LED lights.

Calibration load point marked on handle.

Accuracy  $\pm 2\%$   
Recalibration warning by time and number of cycles

1500 stored values. Large backlight LCD display. Multiple units: Nm, ft-lb and more. Languages: English, Dutch, French, German, Italian, Portuguese, Spanish. Up to 50 presets, counter and job mode.

Range	CW	ACW
20% to 100%	$\pm 2\%$	$\pm 3\%$
5% to 19%	$\pm 4\%$	$\pm 4\%$



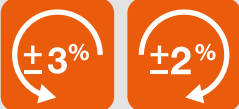

 Bahco Connect App available for Windows 10, iOS and Android at the different stores.

 Bluetooth® real time connectivity to PC or tablet

 Accuracy between 20 and 100% of full scale. (see table)

 Audible beep warning to stop applying force when reaching target torque.

 Sensitive vibration warning to stop applying force when reaching target torque.

 Visual warnings:  
· Progressive yellow LED light indicating 40%, 60%, 80% of target torque achieved.  
· Green LED light indicating target torque achieved.  
· Red LED indicating overtorque.

 Digital torque reading wrench to know the torque/angle being applied at every moment.

 Multiple units available ft.lb, in.lb, in-oz (depending on the range) · Kg.m, Kg.cm, dN.m, cN.m (depending on the range).

 Fixed ratchet head and Rectangular type interchangeable heads for maximum accessibility and versatility

 Declaration of Conformances according to ISO 6789-1:2017 and traceable to international standards



### TAWMB MICRO

#### Bluetooth® Digital Torque and Angle Wrench with Interchangeable Head



- Bluetooth® real-time 2-way data transfer
- Bahco Connect free app available for Windows 10, Android and iOS in 18 languages; Easy to set up and use
- Recalibration warning by time and/or number of cycles
- Re-Do option
- Data download through the app
- Torque Units in Newton.metre, kg.cm, dNewton.metre, ft.lb, lb.in (cNewton.metre & in.oz depending on range), and angle units in degrees
- Can be used CW and CCW at temperatures between 5°C and 42°C
- Memory capacity for 1500 readings and up to 50 presets
- Torque, angle, torque and angle, torque then angle, preset and job modes
- Counter
- Data and set value retention during battery exchange
- Programmable automatic shut-off time
- More advanced configurations and settings available in user manual
- Accurate to ±2% CW - 3% CCW between 20% and 100% of max torque
- Accurate to ±4% CW and CCW between 5% and 19% of full scale
- Visual (dual LEDs + backlit LCD display), audible and vibration signal
- 9x12 interchangeable heads for multiple applications and versatility
- All metal body for high strength and long life
- Battery compartment with reverse threaded end cap for AA alkaline batteries (included)
- Supplied in sturdy blow-moulded case with a declaration of conformity according to ISO 6789-1:2017 traceable to International standards
- CE and UKCA marked; Made in USA

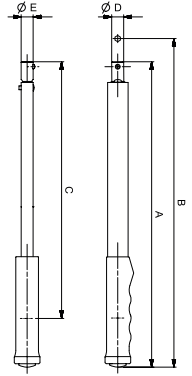

											A	B	C	D	E	
				Nm	in-lb	ft-lb		Nm	in-lb	ft-lb	mm	mm	mm	mm	mm	
TAWMB930M	0489640	1	1.5-30	13.2-265	1.1-22.1	9x12	0.01	0.1	0.01	259	277	211	25	19	0.39	
TAWMB9135M	0490110	1	6.8-135	60-1200	5-100	9x12	0.1	1	0.1	338	355	281	25	19	0.73	



### TAWMB14\_24

#### Bluetooth® Digital Torque and Angle Wrench with Interchangeable Head



- Bluetooth® real-time 2-way data transfer
- Bahco Connect free app available for Windows 10, Android and iOS in 18 languages; Easy to set up and use
- Recalibration warning by time and/or number of cycles
- Re-Do option
- Data download through the app
- Torque units in Newton.metre, kg.cm, dNewton.metre, ft.lb, lb.in, and angle units in degrees
- Can be used CW and CCW at temperatures between 5°C and 42°C
- Memory capacity for 1500 readings and up to 50 presets
- Torque, angle, torque and angle, torque then angle, preset and job modes
- Counter
- Data and set value retention during battery exchange
- Programmable automatic shut-off time
- More advanced configurations and settings available in user manual
- Accurate to ±2% CW - 3% CCW between 20% and 100% of max torque
- Accurate to ±4% CW and CCW between 5% and 19% of full scale
- Visual (dual LEDs + backlit LCD display), audible and vibration signal
- 14x18 & 24x32 interchangeable heads for multiple applications and versatility
- All metal body for high strength and long life
- Battery compartment with reverse threaded end cap for AA alkaline batteries (included)
- Supplied in sturdy blow-moulded case with a declaration of conformity according to ISO 6789-1:2017 traceable to International standards
- CE and UKCA marked; Made in USA

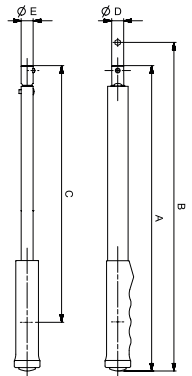

											A	B	C	D	E	
				Nm	in-lb	ft-lb		Nm	in-lb	ft-lb	mm	mm	mm	mm	mm	
TAWMB14340	0489626	1	17-340	150.5-3009	12.5-250	14x18	1	1	1	610	635	530	29	25	1.91	
TAWMB24650	0490103	1	32.5-650	288-5753	24-479.4	24x32	1	1	1	857	892	812	55	25	2.47	
TAWMB24800	0489633	1	40-800	354-7080	29.5-590	24x32	1	1	1	1180	1215	1035	55	40	4.0	

# TORQUE ANGLE WITH USB SLIM

## Digital Torque Angle Slim Wrench with USB





Range	CW	ACW
20% to 100%	±2%	±3%
5% to 19%	±4%	±6%

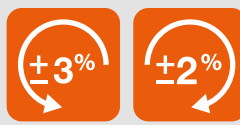

 Plug and play data download to Excel through cable with USB connector.

 Digital torque reading wrench to know the torque/angle being applied at every moment.

 Accuracy (see table).

 Audible beep warning to stop applying force when reaching target torque.

 Sensitive vibration warning to stop applying force when reaching target torque.

 Visual warnings:  
 - Progressive yellow LED light indicating 40%, 60%, 80% of target torque achieved.  
 - Green LED light indicating target torque achieved.  
 - Red LED indicating over-torque.

 Declaration of conformity comes with the product.

 Multiple units available ft.lb, in.lb, in-oz (depending on the range)  
 - kg.m, kg.cm, dN-m, cN-m (depending on the range).

 Fixed ratchet head and rectangular I/H head.



**TAWM930M/TAWM912M/TAWM9135M**  
**Digital Torque Angle Slim Wrench**  
**with USB and Interchangeable Head**



- Torque units in N-m, kg.cm, dN-m, ft.lb, lb.in (cN-m and in.oz depending on range) and angle units in degrees
- Torque range covers from 0.6 to 30 N-m and from 5.3 to 265 in.lb
- It can be used CW and ACW at temperatures between 5 °C and 42 °C
- Memory capacity of 50 readings and up to 10 presets
- Torque, angle, torque then angle and preset modes
- Counter
- Data and set value retention during battery exchange
- Programmable automatic shut-off time
- More advanced configurations and settings available in the user manual
- Accurate to ±2% CW and 3% ACW between 20% and 100% of max torque
- Visual (dual LEDs + backlit LCD display), audio and vibration signal
- 9x12 female rectangular interchangeable head receiver
- All in a metal body and bezel for higher strength and duration
- Metal handle with reverse threaded end cap to enclose AA alkaline batteries (included)
- Supplied in sturdy blow mould case
- Supplied with a factory declaration of conformity and CE marking
- Made in USA

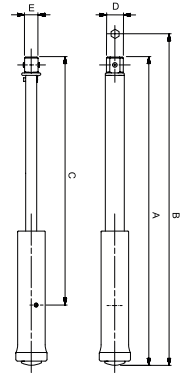

											A	B	C	D	E	
		731415		Nm	in-lb	ft-lb		Nm	in-lb	ft-lb	mm	mm	mm	mm	mm	
TAWM912M	0423132	1	0.6-12	5.3-106	0.44-8.85	9x12	0,01	0,1	0,01		259	277	211	25	19	0.390
TAWM930M	0422241	1	1.5-30	13.2-265	1.1-22.1	9x12	0,01	0,1	0,01		259	277	211	25	19	0.390
TAWM9135M	0502271	1	6.8-135	60-1200	5-100	9x12	0,1	0,1	1		338	355	281	25	19	0.73





**TAWM1430M/TAWM1412M/TAWM38135M**  
**Digital Torque Angle Slim Wrench with USB**  
**and Fixed Ratchet Head**



- Torque units in N-m, kg.cm, dN-m, ft.lb, lb.in and angle units in degrees
- Torque range covers from 0.6 to 30 N-m and from 5.3 to 265 in.lb
- It can be used CW and ACW at temperatures between 5 °C and 42 °C
- Memory capacity of 1,500 readings and up to 50 presets
- Plug and play USB data download to Excel format
- Torque, angle, torque and angle, torque then angle, preset and job modes
- Counter
- Data and set value retention during battery exchange
- Programmable automatic shut-off time
- More advanced configurations and settings available in the user manual
- Accurate to ±2% CW and 3% ACW between 20% and 100% of max torque
- Visual (dual LEDs + backlit LCD display), audio and vibration signal
- ¼" square drive 40-tooth fixed ratchet head
- All in a metal body and bezel for higher strength and duration
- Metal handle with reverse threaded end cap to enclose AA alkaline batteries (included)
- Supplied in sturdy blow mould case
- Supplied with a factory declaration of conformity and CE marking
- Made in USA

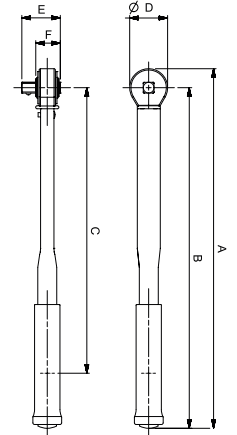

		731415		Nm	ft-lb	in-lb	in	Nm	ft-lb	in-lb	A	B	C	D	E	F	
TAWM1412M	0423149	1	0.6-12	0.44-8.85	5.3-106	1/4	0,01	0,01	0,1	292	280	232	22	21	12	12	0.405
TAWM1430M	0422265	1	1.5-30	1.1-22.1	13.2-265	1/4	0,01	0,01	0,1	292	280	232	22	21	12	12	0.405
TAWM38135M	0502264	1	6.8-135	5-100	60-1200	3/8	0,1	0,1	1	389	376	318	34	34	20	20	0.73





**TAWM9\_14\_24**

**Digital Torque Angle Wrench  
with USB and Interchangeable Head**



- Torque units in N-m, kg.cm, dN-m, ft.lb, lb.in and angle units in degrees
- Torque range covers from 7 to 800 N-m and from 5.1 to 590 ft.lb
- It can be used CW and ACW at temperatures between 5 °C and 42 °C
- Memory capacity of 1,500 readings and up to 50 presets
- Plug and play USB data download to Excel format
- Torque, angle, torque and angle, torque then angle, preset and job modes
- Counter
- Data and set value retention during battery exchange
- Programmable automatic shut-off time
- Programmable recalibration warning
- More advanced configurations and settings available in the user manual
- Accurate to ±2% CW and 3% ACW between 20% and 100% of max torque
- Visual (dual LEDs + backlit LCD display), audio and vibration signal
- With 9x12, 14x18 and 24x32 female rectangular interchangeable head receivers
- All in a metal body and bezel for higher strength and duration
- Metal handle with reverse threaded end cap to enclose AA alkaline batteries (included)
- Supplied in sturdy blow mould case
- Supplied with a factory declaration of conformity and CE marking
- Made in USA

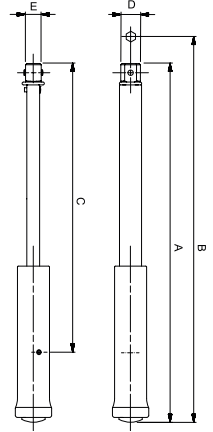

		PAN 731415		Nm	in-lb	ft-lb	mm	Nm	in-lb	ft-lb	A mm	B mm	C mm	D mm	E mm	kg
TAWM9135	0340828	1	7-135	62-1194	5.2-99.5	9x12	1	1	1	450	468	370	25	19	1.170	
TAWM14340	0340835	1	17-340	150.5-3009	12.5-250	14x18	1	1	1	610	635	530	29	25	1.565	
TAWM24800	0368280	1	40-800	354-7080	29.5-590	24x32	1	1	1	1180	1215	1035	55	40	4.100	





# TORQUE ANGLE SLIM

*Digital Torque Angle Slim Wrench with Fixed Ratchet Head*



Range	CW	ACW
20% to 100%	±2%	±3%
10% to 19%	±4%	±6%
5% to 9%	±8%	±10%



Digital torque reading wrench to know the torque/angle being applied at every moment.



Sensitive vibration warning to stop applying force when reaching target torque.



Accuracy: see table above.



Audible beep warning to stop applying force when reaching target torque.



Multiple units available ft.lb, in.lb, in-oz (depending on the range) · kg.m, kg.cm, dN-m, cN-m (depending on the range).



Visual warnings:  
 · Yellow LED light indicating 80% of target torque achieved.  
 · Green LED light indicating target torque achieved.  
 · Red LED indicating over-torque.



Declaration of conformity comes with the product.



Fixed ratchet head with quick release up to 1/2" square drive.



Rectangular interchangeable head in 9x12, 14x18 and 24x32 sizes.



**TAW912M/TAW930M/TAW9135M**  
**Digital Torque Angle Slim Wrench**  
**with Interchangeable Head**



- Torque units in N-m, kg.cm, dN-m, ft.lb, lb.in and angle units in degrees
- Torque range covers from 0.6 to 30 N-m and from 5.3 to 265 in.lb
- It can be used CW and ACW at temperatures between 5 °C and 42 °C
- Memory capacity of 50 readings and up to 10 presets
- Torque, angle, torque then angle and preset modes
- Counter
- Data and set value retention during battery exchange
- Programmable automatic shut-off time
- More advanced configurations and settings available in the user manual
- Accurate to ±2% CW and 3% ACW between 20% and 100% of max torque
- Visual (dual LEDs + backlit LCD display), audio and vibration signal
- 9x12 female rectangular interchangeable head receiver
- All in a metal body and bezel for higher strength and duration
- Metal handle with reverse threaded end cap to enclose AA alkaline batteries (included)
- Supplied in sturdy blow mould case
- Supplied with a factory declaration of conformity and CE marking
- Made in USA

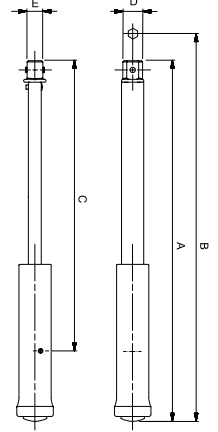

	731415		Nm	in-lb	ft-lb	mm	Nm	in-lb	ft-lb	A mm	B mm	C mm	D mm	E mm	kg
TAW912M	0423163	1	0.6-12	5.3-106	0.44-8.85	9x12	0,01	0,1	0,01	259	277	211	25	19	0.390
TAW930M	0422319	1	1.5-30	13.2-265	1.1-22.1	9x12	0,01	0,1	0,01	259	277	211	25	19	0.390
TAW9135M	0502288	1	6.8-135	60-1200	5-100	9x12	0,1	0,1	1	338	355	281	25	19	0.73





**TAW1430M/TAW1412M/TAW38135M**  
**Digital Torque Angle Slim Wrench**  
**with Fixed Ratchet Head**



- Torque units in N-m, kg.cm, dN-m, ft.lb, lb.in and angle units in degrees
- Torque range covers from 0.6 to 30 N-m and from 5.3 to 265 in.lb
- It can be used CW and ACW at temperatures between 5 °C and 42 °C
- Memory capacity of 50 readings and up to 10 presets
- Torque, angle, torque then angle and preset modes
- Counter
- Data and set value retention during battery exchange
- Programmable automatic shut-off time
- More advanced configurations and settings available in the user manual
- Accurate to  $\pm 2\%$  CW and 3% ACW between 20% and 100% of max torque
- Visual (dual LEDs + backlit LCD display), audio and vibration signal
- 1/4" square drive 40-tooth fixed ratchet head
- All in a metal body and bezel for higher strength and duration
- Metal handle with reverse threaded end cap to enclose AA alkaline batteries (included)
- Supplied in sturdy blow mould case
- Supplied with a factory declaration of conformity and CE marking
- Made in USA

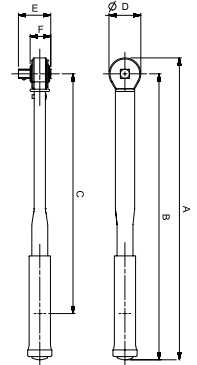

											A	B	C	D	E	F	
		731415		Nm	in-lb	ft-lb	in	Nm	in-lb	ft-lb	mm	mm	mm	mm	mm	mm	
TAW1412M	0423156	1	0.6-12	5.3-106	0.44-8.85	1/4	0,01	0,1	0,01	292	280	232	22	21	12	0.405	
TAW1430M	0422289	1	1.5-30	13.2-265	1.1-22.1	1/4	0,01	0,1	0,01	292	280	232	22	21	12	0.405	
TAW38135M	0502295	1	6.8-135	60-1200	5-100	3/8	0,1	1	0,01	389	376	318	34	34	20	0.73	







**TAW**

**Digital Torque Angle Wrench  
with Fixed Ratchet Head**



- Torque units in N-m, kg.cm, dN-m, ft.lb, lb.in and angle units in degrees
- Torque range covers from 7 to 800 N-m and from 5.1 to 590 ft.lb
- It can be used CW and ACW at temperatures between 5 °C and 42 °C
- Memory capacity of 50 readings and up to 10 presets
- Torque, angle, torque then angle and preset modes
- Counter
- Data and set value retention during battery exchange
- Programmable automatic shut-off time
- Programmable recalibration warning
- More advanced configurations and settings available in the user manual
- Accurate to ±2% CW and 3% ACW between 20% and 100% of max torque
- Visual (dual LEDs + backlit LCD display), audio and vibration signal
- 40-tooth fixed ratchet heads from ¼" to ¾" square drives
- Bezel in ABS and all-metal body for higher strength and duration
- Metal handle with reverse threaded end cap to enclose AA alkaline batteries (included)
- Supplied in sturdy blow mould case
- Supplied with a factory declaration of conformity and CE marking
- Made in USA

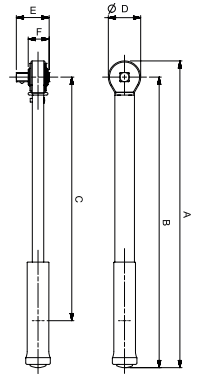

											A	B	C	D	E	F	
	731415			Nm	in-lb	ft-lb	in	Nm	in-lb	ft-lb	mm	mm	mm	mm	mm	mm	
TAW38135	0274956	1	7-135	62-1194	5.2-99.5	3/8	1	1	1	475	460	380	28	28	15	1.270	
TAW12340	0274963	1	17-340	150.5-3009	12.5-250	1/2	1	1	1	670	650	570	35	35	18	1.910	
TAW34800	0285471	1	40-800	354-7080	29.5-590	3/4	1	1	1	1235	1198	1053	60	55	40	4.850	







Scale markings on the torque wrench handle, including values like 10, 20, 30, 40, 50, 60, 70, 80, 90, 100, 110, 120, 130, 140, 150, 160, 170, 180, 190, 200.

40-200 N.m  
79108262422  
↑

BAHGO

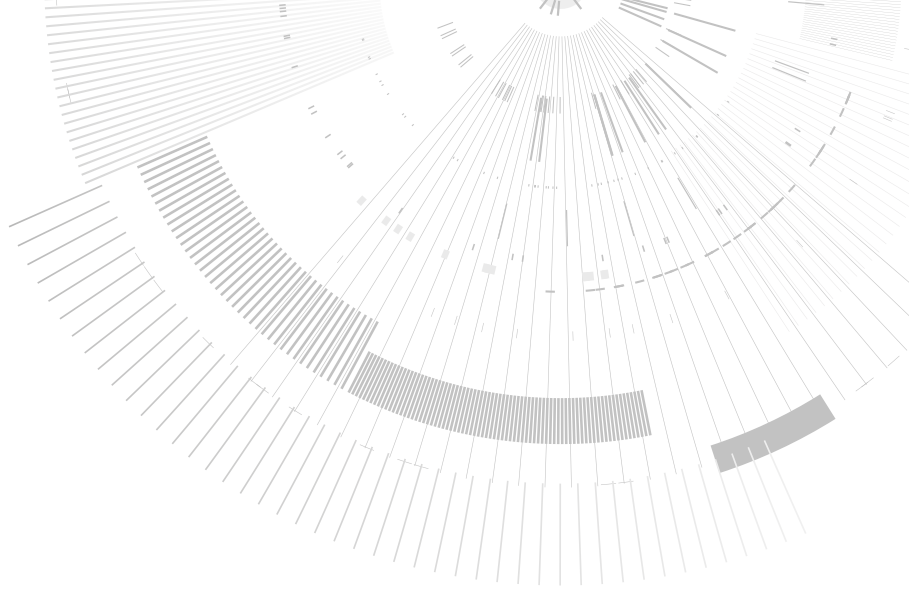

Mechanical torque wrenches are the most used torque wrenches across many different applications. BAHCO offers one of the largest selection of mechanical torque tools, providing the durability, reliability and accuracy needed to turn and tighten fasteners at the right specification.

BAHCO range includes a broad variety of click wrenches (window click, free hand point, all metal clicker wrench, specials for use at height, non-sparking and preset click), apart from breaking wrench models (standard and for use at height) and dial reading wrenches.

This range ensures we cover all needs in most applications, allowing fastening from 1 to 2500 N-m.  
Choose BAHCO for total control.

# **MECHANICAL** TORQUE WRENCHES

- *Adjustable Window Click Wrenches*
- *Adjustable Free-Hand Point Click Wrenches*
- *Adjustable Marked Scale Click Wrenches*
- *Torque Tools at Height*
- *Non Sparking Torque Tools*
- *Adjustable Window Breaking Wrenches*
- *Dial Wrenches*
- *Preset Click Wrenches*

# ADJUSTABLE WINDOW CLICK WRENCHES

## Adjustable Window Click Wrench with Fixed Ratchet Head



Durable and accurate clicking mechanism working in one single direction with more than 100,000 cycles within  $\pm 3\%$  accuracy.

Highly visible dual scale (N-m and in.lb or N-m and ft.lb) in a window to protect against wear and tear.

Soft-touch hand grip made with material resistant to the most common chemicals where wrenches might be used.

Ergo texture for optimum grip when turning the handle for torque setting.

Centre of handle grip is marked with two orange squares in order to identify the position of the hand and therefore the force loading point when operating and calibrating the wrench.

Torque setting lock/unlock knob. Highly visible blue ring at unlocked position.

Ratchet head with a movable square drive to allow operating the wrench CW and ACW (except 15 N-m and 25 N-m). Interchangeable options also available in 9x12, 14x18 and 16 mm spigot.

The serial number can be laser etched on the wrench and on a label with a barcode for easy scanning and recording. Serial number is also included on the declaration of conformity that comes with the tool.



Audible click warning to stop applying torque.



Sensitive click warning to stop applying torque.



Female rectangular interchangeable head in 9x12 and 14x18 sizes also available on 74W9 and 74W14 models (3-400 N-m).



Declaration of conformity comes with the product.



Fixed reversible only optional CW on 74WR-15 and 25 (3 - 25 N-m).



Fixed push-through ratchet heads available in sizes, 74WR-50 to 400 allowing CW and ACW operations (10-400 N-m).



Large dual scale in N-m/ft.lb (15 and 25 N-m wrench sizes in N-m/in.lb).



Full range delivered in a semi-transparent square hanging tube.



16 mm spigot I/H head available in 74 WS models (3-300 N-m).



Accuracy  $\pm 3\%$  Clockwise. Anticlockwise.

**74WR-15/74WR-25**

**Adjustable Torque Click Wrench with Window Scale and Fixed Ratchet Head**



- Durable mechanism with over 100,000 cycles within accuracy
- Fast scale adjustment reducing the effort required to adjust
- Large dual scale in N-m/in.lb
- Range covering from 3 to 25 N-m/27 - 220 in.lb torque values
- Can only be used clockwise
- Accurate to  $\pm 3\%$  of reading which exceeds the requirements of ISO6789-1:2017
- Clicking system triggers a tactile and audible signal
- Reversible ratchet head with 1/4" square drives allowing CW operation only
- Handle centre or calibration force point marked on handle
- Lock/unlock knob with blue ring inside to warn the operator the wrench is unlocked
- In a semi-transparent square tube with eurohole hanger
- All wrenches come with a factory calibration certificate according to ISO 6789-2:2017
- Made in the UK

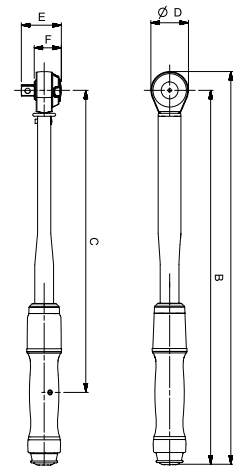

									A	B	C	D	E	F	
				Nm	in-lb	in	Nm	ft-lb	mm	mm	mm	mm	mm	mm	
74WR-15	0415519	1	3-15	27-132	1/4	0,2	2	221	209	140	25	25	18	0.300	
74WR-25	0415526	1	5-25	44-220	1/4	0,2	2	221	209	140	25	25	18	0.300	

**74WR-50/74WR-400**

**Adjustable Torque Click Wrench with Window Scale and Fixed Push-Through Ratchet Head**



- Durable mechanism with over 100,000 cycles within accuracy
- Fast scale adjustment reducing the effort required to adjust
- Large dual scale in N-m/ft.lb
- Range covering from 10 and 400 N-m/7.5 - 300 ft.lb torque values
- Can be used clockwise or anticlockwise by pushing across the square drive of the ratchet head
- Accurate to  $\pm 3\%$  of reading which exceeds the requirements of ISO6789-1:2017
- Clicking system triggers a tactile and audible signal
- Push-through ratchet heads from 3/8" to 1/2" square drives allowing CW and ACW operations
- Handle centre or calibration force point marked on handle
- Lock/unlock knob with blue ring inside to warn the operator the wrench is unlocked
- In a semi-transparent square tube with eurohole hanger
- All wrenches come with a factory calibration certificate according to ISO 6789-2:2017
- Made in the UK

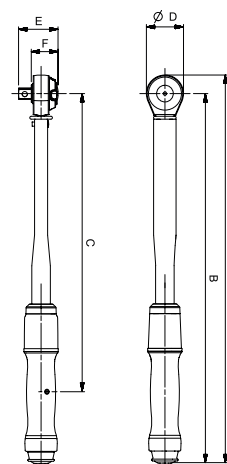

									A	B	C	D	E	F	
				Nm	ft-lb	in	Nm	ft-lb	mm	mm	mm	mm	mm	mm	
74WR-50	0415533	1	10-50	7.5-37.5	3/8"	0,5	0,5	335	317	231	35	37	26	0.700	
74WR-100	0415540	1	20-100	15-75	1/2"	1	1	387	364	278	45	48	32	0.900	
74WR-200	0415557	1	40-200	30-150	1/2"	2	2	470	447	361	45	48	32	1.100	
74WR-300	0415564	1	60-300	45-220	1/2"	2	2	593	567	480	52	48	33	1.400	
74WR-340	0415571	1	60-340	45-250	1/2"	5	2	685	659	572	52	48	33	1.500	
74WR-400	0415588	1	80-400	60-300	3/4"	5	5	686	661	574	51	47	24	1.900	





**74WS-15/74WS-300**

**Adjustable Torque Click Wrench  
with Window Scale and Spigot Interchangeable Head**



- Durable mechanism with over 100,000 cycles within accuracy
- Fast scale adjustment reducing the effort required to adjust
- Large dual scale in N-m/ft.lb (15 and 25 N-m wrench sizes in N-m/in.lb)
- Range covering from 3 and 300 N-m/27 in.lb - 220 ft.lb torque values
- Can be used clockwise or anticlockwise by turning the wrench over
- Accurate to ±3% of reading which exceeds the requirements of ISO6789-1:2017
- Clicking system triggers a tactile and audible signal
- 16 mm spigot interchangeable head allowing CW and ACW operations
- Handle centre or calibration force point marked on handle
- Lock/unlock knob with blue ring inside to warn the operator the wrench is unlocked
- In a semi-transparent square tube with eurohole hanger
- All wrenches come with a factory calibration certificate according to ISO 6789-2:2017
- Made in the UK

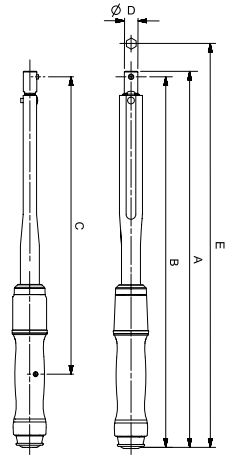

										A	B	C	E	
	731415		Nm	ft-lb	in-lb	mm	Nm	ft-lb	in-lb	mm	mm	mm	mm	kg
74WS-15	0415595	1	3-15	-	27-132	16	0,2	-	2	223	216	148	248	0.300
74WS-25	0415601	1	5-25	-	44-220	16	0,2	-	2	223	216	148	248	0.300
74WS-50	0415618	1	10-50	7.5-37.5	-	16	0,5	0,5	-	322	316	229	348	0.600
74WS-100	0415625	1	20-100	15-75	-	16	1	1	-	363	356	269	388	0.700
74WS-200	0415632	1	40-200	30-150	-	16	2	2	-	445	438	351	470	0.900
74WS-300	0415649	1	60-300	45-220	-	16	2	2	-	569	563	476	595	1.200

**74W9/74W14**

**Adjustable Torque Click Wrench  
with Window Scale and Rectangular Interchangeable Head**



- Durable mechanism with over 100,000 cycles within accuracy
- Fast scale adjustment reducing the effort required to adjust
- Large dual scale in N-m/ft.lb (15 and 25 N-m wrench sizes in N-m/in.lb)
- Range covering from 3 and 400 N-m/27 in.lb - 300 ft.lb torque values
- Can be used clockwise or anticlockwise by turning the wrench over
- Accurate to ±3% of reading which exceeds the requirements of ISO6789-1:2017
- Clicking system triggers a tactile and audible signal
- 9x12 and 14x18 rectangular female interchangeable heads allowing CW and ACW operations
- Handle centre or calibration force point marked on handle
- Lock/unlock knob with blue ring inside to warn the operator the wrench is unlocked
- In a semi-transparent square tube with eurohole hanger
- All wrenches come with a factory calibration certificate according to ISO 6789-2:2017
- Made in the UK

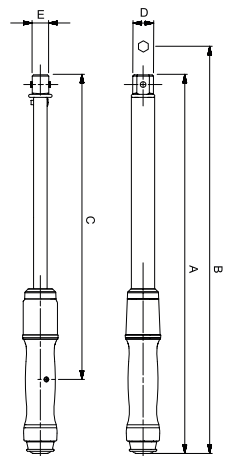

										A	B	C	D	E	
	731415		Nm	ft-lb	in-lb	mm	Nm	ft-lb	in-lb	mm	mm	mm	mm	mm	kg
74W9-15	0415656	1	3-15	-	27-132	9x12	0,2	-	2	218	236	153	22	20	0.300
74W9-25	0415663	1	5-25	-	44-220	9x12	0,2	-	2	218	236	153	22	20	0.300
74W9-50	0415670	1	10-50	7.5-37.5	-	9x12	0,5	0,5	-	325	343	238	22	20	0.600
74W9-100	0415687	1	20-100	15-75	-	9x12	1	1	-	365	383	278	22	20	0.700
74W9-200	0415694	1	40-200	30-150	-	9x12	1	2	-	442	460	356	25	20	0.900
74W14-200	0415700	1	40-200	30-150	-	14x18	2	2	-	453	478	366	34	26	1.000
74W14-300	0415717	1	60-300	45-220	-	14x18	2	2	-	570	595	453	34	28	1.200
74W14-400	0415724	1	80-400	60-300	-	14x18	5	5	-	664	689	578	32	24	1.700



# ADJUSTABLE FREE-HAND POINT CLICK WRENCHES

## Mechanical Adjustable Free-Hand Point Torque Click Wrench with Fixed Ratchet Head

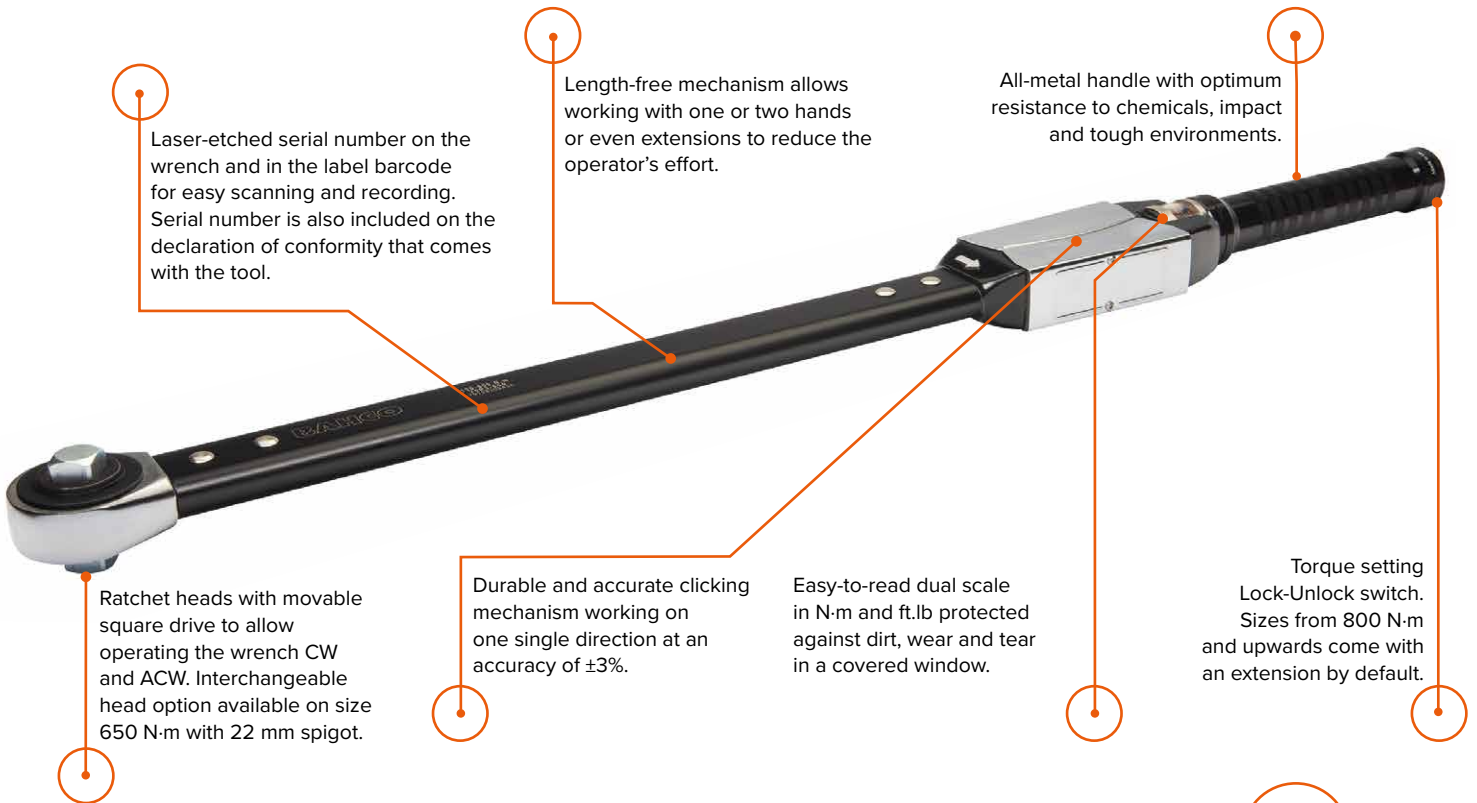

Laser-etched serial number on the wrench and in the label barcode for easy scanning and recording. Serial number is also included on the declaration of conformity that comes with the tool.

Length-free mechanism allows working with one or two hands or even extensions to reduce the operator's effort.

All-metal handle with optimum resistance to chemicals, impact and tough environments.

Ratchet heads with movable square drive to allow operating the wrench CW and ACW. Interchangeable head option available on size 650 N-m with 22 mm spigot.

Durable and accurate clicking mechanism working on one single direction at an accuracy of  $\pm 3\%$ .

Easy-to-read dual scale in N-m and ft.lb protected against dirt, wear and tear in a covered window.

Torque setting Lock-Unlock switch. Sizes from 800 N-m and upwards come with an extension by default.

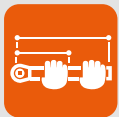

Free-hand point or non-length-dependent feature.



Audible click warning to stop applying torque.



Sensitive click warning to stop applying torque.



Calibration certificate according to ISO 6789-2:2017 traceable to International Standards



Dual scale display.



Full range on portable blow mould cases.



Spigot male interchangeable head in 22 mm on 75S.



Movable square drive ratchet head on 75WR model.



Accuracy  $\pm 3\%$  Clockwise Anticlockwise.





**75R3/75R1**

**Mechanical Adjustable Free-Hand Point Torque Click Wrench with Fixed Ratchet Head**



- Non-length-dependant so can be used with or without the supplied extension handle (optional on 650 N-m)
- Large dual scale in N-m/ft.lb
- Range covering from 130 to 1,500 N-m/100 - 1,100 ft.lb torque values
- Can be used clockwise or anticlockwise by pushing across the square drive of the ratchet head
- Accurate to ±3% of reading which exceeds the requirements of ISO6789-1:2017
- Exceptionally clear torque signal from the unique mechanism
- Push-through ratchet heads allowing CW and ACW operation
- Extension handle significantly reduces operator effort to achieve high torque values
- All in a portable sturdy blow mould case
- All wrenches come with a factory calibration certificate according to ISO 6789-2:2017
- Made in the UK

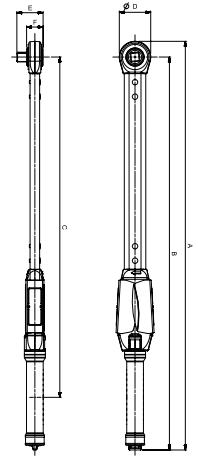

	731415		Nm	ft-lb	in	Nm	ft-lb	A mm	B mm	C mm	D mm	E mm	F mm	kg
75R3-650	0415205	1	130-650	100-480	3/4"	5	5	856	823	713	66	56	30	4.000
75R3-800	0415212	1	200-800	150-600	3/4"	10	5	1037	999	889	75	58	33	5.200
75R3-1000	0415229	1	300-1000	220-750	3/4"	10	5	1245	1208	1097	75	58	38	5.800
75R1-1500	0415236	1	500-1500	370-1100	1"	10	10	1571	1533	1422	75	66	38	6.700





### 75S-650

## Mechanical Adjustable Free-Hand Point Torque Click Wrench with Spigot Interchangeable Head



- Non-length-dependant so can be used with or without extension handle (optional)
- Large dual scale in N-m/ft.lb
- Range covering from 130 to 650 N-m/100 - 480 ft.lb torque values
- Can be used clockwise or anticlockwise by turning the wrench over
- Accurate to  $\pm 3\%$  of reading which exceeds the requirements of ISO6789-1:2017
- Exceptionally clear torque signal from the unique mechanism
- 22 mm spigot interchangeable head allowing CW and ACW operations
- Extension handle significantly reduces operator effort to achieve high torque values
- All in a portable sturdy blow mould case
- All wrenches come with a factory calibration certificate according to ISO 6789-2:2017
- Made in the UK

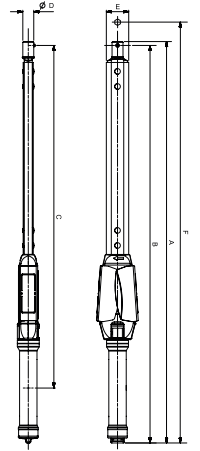

									A	B	C	E	F	
		731415		Nm	ft-lb	mm	Nm	ft-lb	mm	mm	mm	mm	mm	
75S-650		0415243	1	130-650	100-480	22	5	5	807	799	688	45	855	3.600



### 75EXT

## Extension



- Free-hand point wrenches are non-length-dependent wrenches, therefore allowing the use of extensions to achieve the target torque
- Extension has a ring in order to lock/unlock the extension to the free-hand point wrenches by applying a half turn on it
- Extension handle significantly reduces operator effort to achieve high torque values

				L		
		731415		mm		
75EXT		0415311	1	700	60	1.600



# ADJUSTABLE MARKED SCALE CLICK WRENCHES

All metal Adjustable Click Wrench with Marked Scale and Fixed Ratchet Head

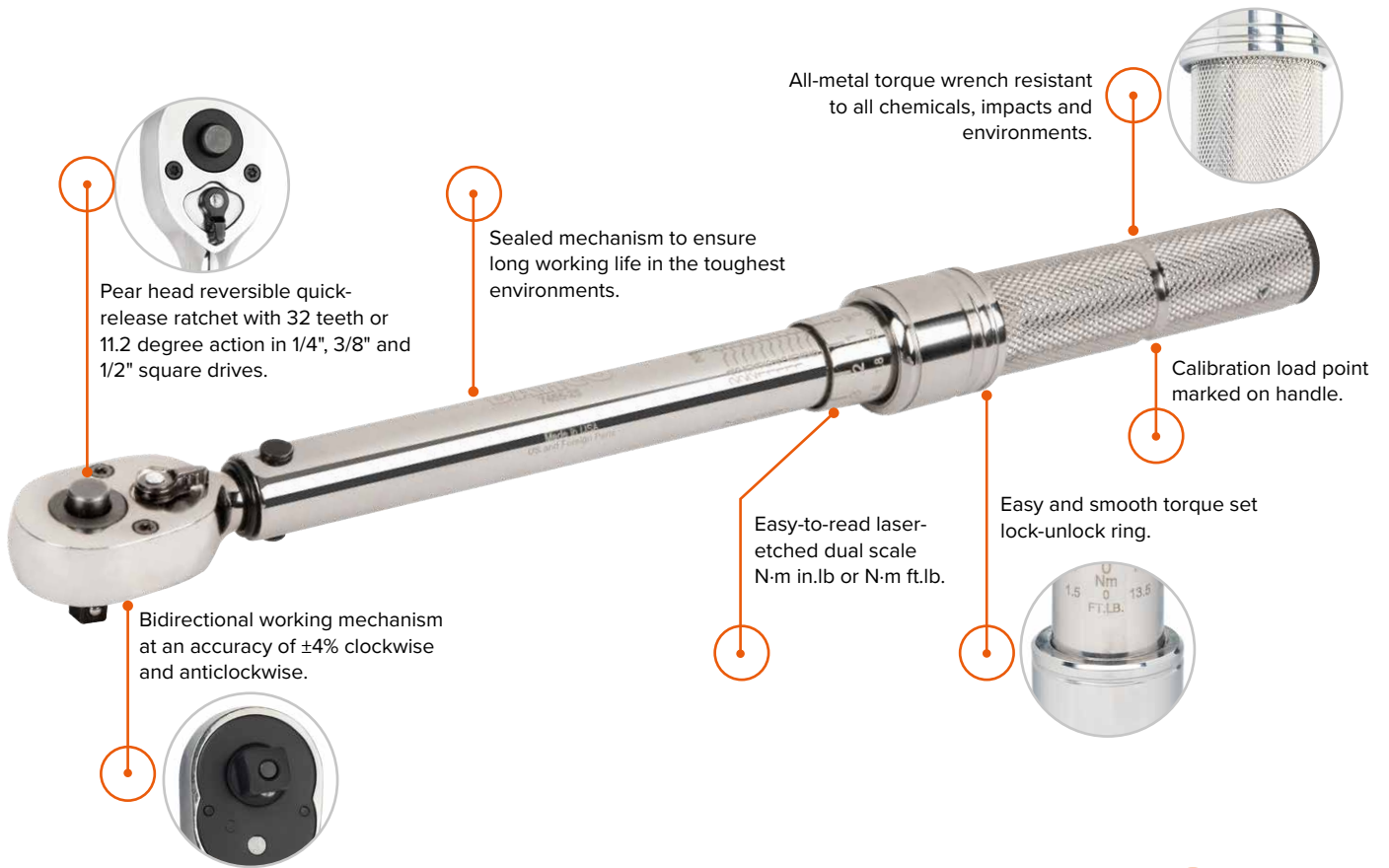

Indicates click warning to stop applying torque.



7455 up to 1,500 N-m with fixed ratchet head.



Accuracy to  $\pm 4\%$  Clockwise. Anticlockwise.



All wrenches supplied with a declaration of conformity.



Sensitive click warning to stop applying torque.



7465 version up to 1,500 N-m with 9x12, 14x18, 24x32 and 27x36 interchangeable heads.



Dual scale in N-m/lb.in or N-m/ft.lb.





**7455-1500**

**Adjustable Torque Click Wrench with Marked Scale, Fixed Ratchet Head and 2 Section Handle**



- Dual scale in N-m/ft.lb
- Controlled torque application events to  $\pm 4\%$  CW and ACW
- Clicking system triggers a tactile and audible signal
- Fixed ratchet head with 24 teeth in 1" square drive
- All-metal rugged, durable wrench with sealed mechanism
- Supplied in two pieces which need to be assembled for use and calibration
- Supplied in a metal case with foam
- Supplied with a factory declaration of conformity according to ISO 6789-1:2017
- Made in USA

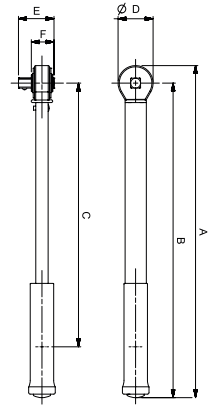

								A	B	C	D	E	F	
7455-1500	0125166	1	Nm	ft-lb	in	Nm	ft-lb	mm	mm	mm	mm	mm	mm	kg
			300-1500	258-1069	1	10	7,4	1780	1740	1690	78	68	38	11.395



**7455-2500**

**Adjustable Torque Click Wrench with Marked Scale and Fixed Square Drive and 3 Section Handle**



- Dual scale N-m/ft.lb
- Can be used clockwise
- Controlled torque application events to  $\pm 4\%$  CW
- Clicking system triggers a tactile and audible signal
- Fixed square drive head without a ratcheting mechanism for high torque application
- All-metal rugged, durable wrench with sealed mechanism
- Supplied in three pieces which need to be assembled for use and calibration
- Supplied with a factory declaration of conformity according to ISO 6789-1:2017
- Made in USA

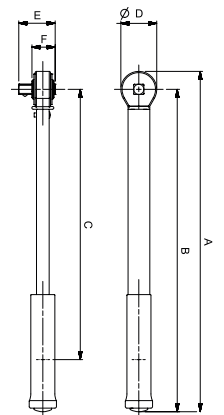

								A	B	C	D	E	F	
7455-2500	0125173	1	Nm	ft-lb	in	Nm	ft-lb	mm	mm	mm	mm	mm	mm	kg
			500-2500	406-1807	1	10	7,4	2720	2675	2625	99	108	75	24.120







# ADJUSTABLE CLICK WRENCH FOR USE AT HEIGHT

*Double Square Head Adjustable Click Wrench with Tethered Point to Work at Height*



Pinned square drives for safe use at height

Highly visible dual scale for easy and precise setting

Double square ratchet for use clockwise and anticlockwise

Durable and reliable clicking mechanism ensures accuracy for long period of time

Tethered point to safely fix your lanyard and avoid potential tool drops

Locking knob keeps torque value setting during use. Triangular shaped hook eases unlocking the knob with greasy hands.



Drops compliant torque wrench with fixed tethered point and pinned square drives



Indicates click warning to stop applying torque.



Double square drive round type ratchet head for clockwise and anticlockwise use



Sensitive click warning to stop applying torque.



All wrenches supplied with a declaration of conformity.



Dual scale in N-m/lb.in or N-m/ft.lb.



Accuracy  $\pm 3\%$   
Clockwise.  
Anticlockwise.

**TAH73R-100**

**Mechanical Adjustable Torque Click Wrench with Marked Scale and Fixed Ratchet Head with Metallic Plate**



- Large dual scale in N-m and ft-lb
- Range covering from 20 to 300 N-m and from 20 to 220 ft.lb
- Can be used clockwise and counterclockwise thanks to its double square drive head
- Pinned square drives in line with DROPS for safe handling of sockets when working at height
- Accurate to  $\pm 3\%$  of reading which exceeds the requirements of ISO 6789-1:2017
- Clicking system triggers a tactile and audible signal
- Tough ratchet with 50-60 teeth allow narrow engagement angles ideal to work in confined spaces (5° up to 200 N-m and 6° for 300 N-m)
- Triangle shaped wire attached to adjusting knob eases unlocking operation with greasy hands
- All wrenches come with a declaration of conformity according to ISO 6789-1:2017
- Made in UK
- Suitable for working at height
- Permanently fixed metallic plate maintains user ergonomics and full functionality
- According to DROPS best practices
- Every wrench is certified by a third party laboratory (TESICNOR).

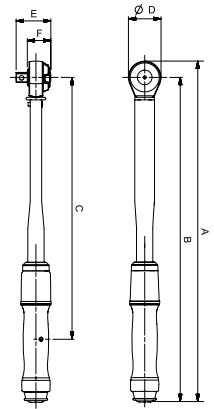

								A	B	C	D	E	F	
	731415		Nm	ft-lb	in	Nm	ft-lb	mm	mm	mm	mm	mm	mm	
TAH73R-100	0503810	1	20-100	20-80	1/2"	1	2	375	354	252	42	53	38	0.9
TAH73R-200	0503834	1	40-200	30-150	1/2"	1	2	459	437	335	45	59	44	1.1
TAH73R-300	0503858	1	60-300	45-220	1/2"	1	5	589	562	460	54	59	44	1.5

**TAH74W9**

**Torque Wrenches with Interchangeable Head and Wire Loop**

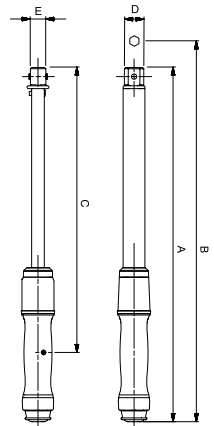

- Durable, reliable and accurate mechanism and fast scale adjustment
- TIMESTRIP visual indication that the wrench is due for re-calibration
- Accurate to  $\pm 3\%$  of reading which exceeds the requirements of ISO6789-1:2017
- Can be used clockwise or anticlockwise by turning the wrench over
- Clicking system triggers a tactile and audible signal
- Lock/unlock knob with blue ring inside to warn the operator the wrench is unlocked
- Large dual scale in N-m/ft.lb
- Handle centre or calibration force point marked on handle
- All wrenches come with a factory calibration certificate according to ISO 6789-2:2017
- In a semi-transparent square tube with eurohole hanger
- Made in the UK
- Suitable for working at height
- Permanently fixed metallic wire loop maintains user ergonomics and full functionality
- Colour plate with maximum weight for a right matching with the lanyard
- According to DROPS best practices

								A	B	C	D	E	
	731415		Nm	ft-lb		Nm	ft-lb	mm	mm	mm	mm	mm	
TAH74W9-100	0519354	1	20-100	15-75	9x12	1	1	365	383	278	22	20	0.70



# NON SPARKING CLICK TORQUE WRENCHES

*Cu-Be and Al-Br Non Sparking Window Click Adjustable Torque Wrenches*

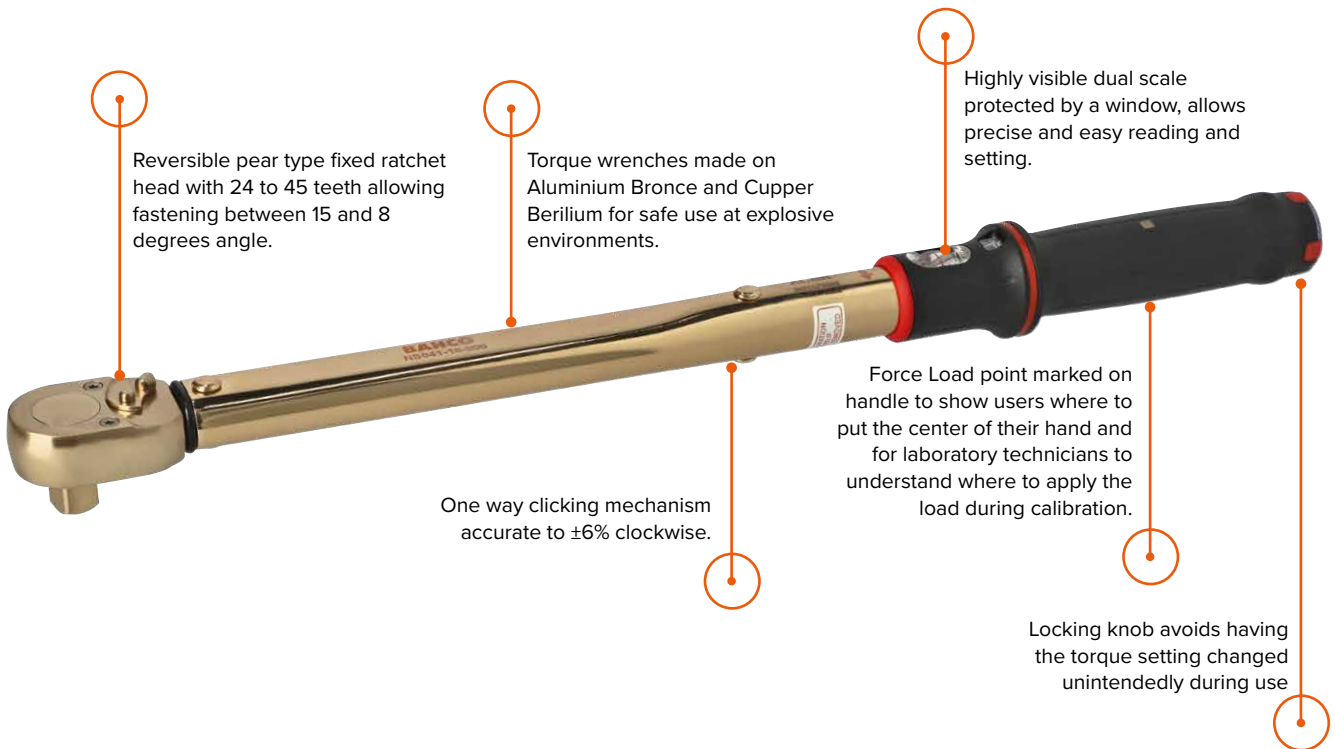

Indicates click warning to stop applying torque.



Reversible pear type ratchet with 24 to 45 teth depending on the wrench size



One way clicking mechanism accurate to  $\pm 6\%$  clockwise



Cu-Be  
Materials certified by external laboratory BAM. Certificates available at Bahco.com



Sensitive click warning to stop applying torque.



All wrenches supplied with a declaration of conformity.



Dual scale in N-m/lb.in or N-m/ft.lb.



Al-Br  
Materials certified by external laboratory BAM. Certificates available at Bahco.com



**NS041**

**Non-Sparking Mechanical Adjustable Torque Click Wrenches with Window Scale and Fixed Ratchet Head in Aluminium Bronze**



- Made of aluminium bronze
- Large dual scale in N.m/ft.lb
- Reversible ratchet head allowing clockwise operation only
- Micrometer and main scale for adjustment
- Sturdy plastic handle with a nice positive lock which engages or disengages clearly
- Good positive audible engagement and the wrench always returns to home after each test
- Accurate to  $\pm 6\%$  of reading
- Ratchet with 24-45 teeth and easy-change direction lever on top of the head
- Supplied with a declaration of conformity traceable to international standards
- All in individual rigid case for maximum protection and storage
- Non-sparking (NS) tools designed for use in potentially explosive environments, where conventional steel tools may produce sparks

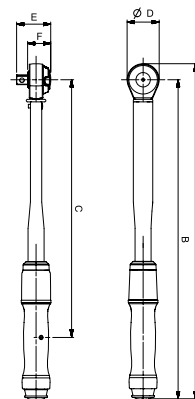

								A	B	C	D	E	F	kg
	731415			Nm	ft-lb	in	Nm	ft-lb	mm	mm	mm	mm	mm	mm
NS041-8-25	0502646	1	5-25	3.75-18.75	1/4"	0.2	0.15	290	277	214	27	13,5	20,5	0.41
NS041-12-50	0502547	1	10-50	7.5-37.5	3/8"	0.5	0.37	360	340	270	40	33	22,5	0.93
NS041-16-100	0502561	1	20-100	15-75	1/2"	0.5	0.37	405	385	315	40	37	22	1.03
NS041-16-200	0502332	1	40-200	30-150	1/2"	1	0,74	500	480	410	40	37	22	1.22
NS041-16-260	0502585	1	60-260	45-195	1/2"	1.5	1.11	595	575	505	40	37	22	1.42
NS041-24-670	0502608	1	150-670	110-500	3/4"	2.5	1.84	1150	1139	1069	63	55,5	33,5	5.62
NS041-32-900	0502622	1	200-900	150-675	1"	5	3.69	1245	1234	1164	63	60,5	33,5	7.13

**NSB041**

**Non-Sparking Mechanical Adjustable Torque Click Wrenches with Window Scale and Fixed Ratchet Head in Copper Beryllium**



- Made of aluminium bronze
- Large dual scale in N.m/ft.lb
- Reversible ratchet head allowing clockwise operation only
- Micrometer and main scale for adjustment
- Sturdy plastic handle with a nice positive lock which engages or disengages clearly
- Good positive audible engagement and the wrench always returns to home after each test
- Accurate to  $\pm 6\%$  of reading
- Ratchet with 24-45 teeth and easy-change direction lever on top of the head
- Supplied with a declaration of conformity traceable to international standards
- All in individual rigid case for maximum protection and storage
- Non-sparking (NS) tools designed for use in potentially explosive environments, where conventional steel tools may produce sparks
- Anti-magnetic and highly corrosion resistant

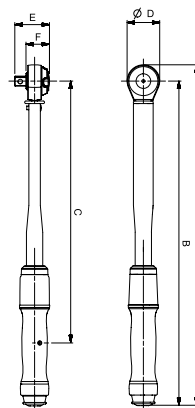

								A	B	C	D	E	F	kg
	731415			Nm	ft-lb	in	Nm	ft-lb	mm	mm	mm	mm	mm	mm
NSB041-8-25	0502769	1	5-25	3.75-18.75	1/4"	0.2	0.15	290	277	214	27	13,5	20,5	0.42
NSB041-12-50	0502660	1	10-50	7.5-37.5	3/8"	0.5	0.37	360	340	270	40	33	22,5	0.96
NSB041-16-100	0502684	1	20-100	15-75	1/2"	0.5	0.37	405	385	315	40	37	22	1.07
NSB041-16-200	0502318	1	40-200	30-150	1/2"	1	0,74	500	480	410	40	37	22	1.28
NSB041-16-260	0502707	1	60-260	45-195	1/2"	1.5	1.11	595	575	505	40	37	22	1.50
NSB041-24-670	0502721	1	150-670	110-500	3/4"	2.5	1.84	1150	1139	1069	63	55,5	33,5	5.75
NSB041-32-900	0502745	1	200-900	150-675	1"	5	3.69	1245	1234	1164	63	60,5	33,5	7.25

# BREAKING WRENCHES

## Adjustable Window Scale Breaking Torque Wrench

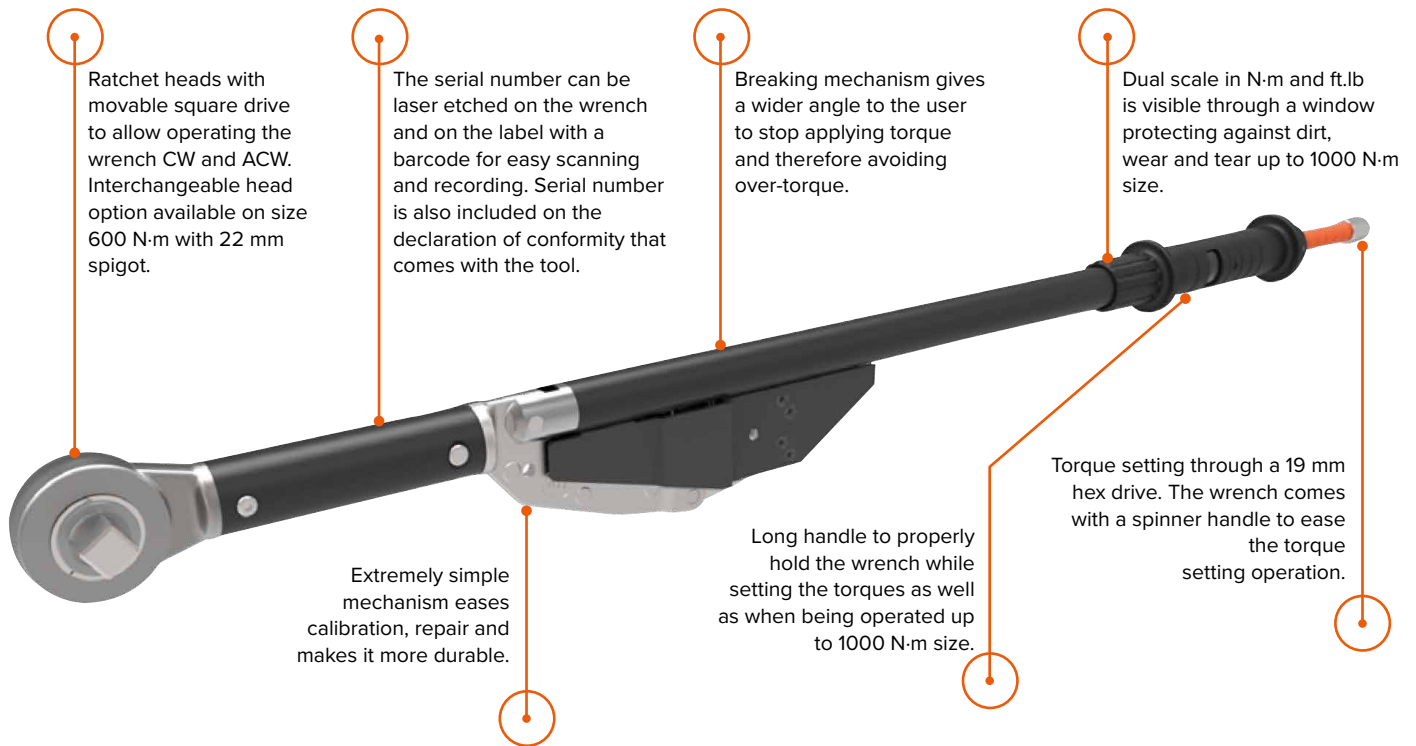

Ratchet heads with movable square drive to allow operating the wrench CW and ACW. Interchangeable head option available on size 600 N-m with 22 mm spigot.

The serial number can be laser etched on the wrench and on the label with a barcode for easy scanning and recording. Serial number is also included on the declaration of conformity that comes with the tool.

Breaking mechanism gives a wider angle to the user to stop applying torque and therefore avoiding over-torque.

Dual scale in N-m and ft.lb is visible through a window protecting against dirt, wear and tear up to 1000 N-m size.

Extremely simple mechanism eases calibration, repair and makes it more durable.

Long handle to properly hold the wrench while setting the torques as well as when being operated up to 1000 N-m size.

Torque setting through a 19 mm hex drive. The wrench comes with a spinner handle to ease the torque setting operation.



Break-back wrench with a wider angle; extra time for stopping after reaching target torque avoiding over-torque.



Indicates click warning to stop applying torque.



Sensitive click warning to stop applying torque.



Declaration of conformity comes with the product.



Dual scale in N-m/ft.lb.



Breaking system triggers a visual signal.



Supplied in portable blow mould cases.



Square drive can be placed at either side of the ratchet head to operate the wrench CW or ACW



Accuracy  $\pm 4\%$  Clockwise. Anticlockwise.





### 76R3

#### Adjustable Window Scale Breaking Torque Wrench



- When reaching the target torque the wrench seems to 'break' in the middle which drastically reduces the risk of over-torque
- Dual scale in N-m/ft.lb
- Range covering from 120 to 1,000 N-m/100 to 750 ft.lb torque values
- Can be used clockwise or anticlockwise by turning the wrench over
- Accurate to ±4% of reading
- Breaking system triggers a visual, tactile and audible signal
- Push-through ratchet heads allowing CW and ACW operation
- Delivered in two parts for when storage space is limited such as vehicle tool kits
- Scale is visible and protected by a window on the handle
- All in a portable sturdy blow mould case
- All wrenches come with a factory declaration of conformity according to ISO 6789-1:2017
- Made in the UK

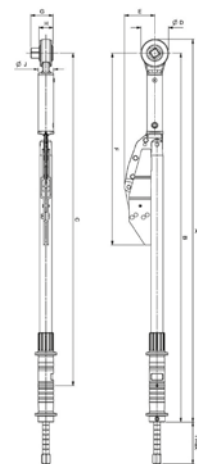

									A	B	C	D	E	F	H	I max	J	
		731415		Nm	ft·lb	in	Nm	ft·lb	mm	mm	mm	mm	mm	mm	mm	mm	mm	kg
76R3-600	0423118	1	120-600	100-450	3/4	10	10	954	69	829	69	75	479	35	105	38	6.6	
76R3-800	0422111	1	200-800	150-600	3/4	10	10	1214	1180	1089	69	75	738	35	105	38	7.3	
76R3-1000	0422128	1	300-1000	200-750	3/4	20	10	1449	1415	1324	69	75	974	35	105	38	7.9	



### 76R3-1500

#### Adjustable Breaking Torque Wrench



- When reaching the target torque the wrench seems to 'break' in the middle which drastically reduces the risk of over-torque
- Dual scale in N-m/ft.lb
- Can be used clockwise or anticlockwise by pushing across the square drive of the ratchet head
- Accurate to ±4% of reading
- Breaking system triggers a visual and tactile signal
- Delivered in two parts for when storage space is limited such as vehicle tool kits
- Scale is laser etched at 2 ends of the hex bar at the end of the handle
- All in a portable sturdy blow mould case
- Supplied with a factory declaration of conformity according to ISO 6789-1:2017
- Made in the UK

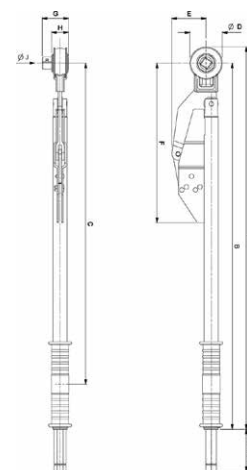

									A	B	C	D	E	F	H	I max	J	
		731415		Nm	ft·lb	in	Nm	ft·lb	mm	mm	mm	mm	mm	mm	mm	mm	mm	kg
76R3-1500	0422135	1	700-1500	500-1000	3/4"	25	25	1764	1730	1635	69	75	1379	35	105	38	9.6	

**76R1-2000**

*Adjustable Breaking Torque Wrench with Double Adjusting Bar*



- When reaching the target torque the wrench seems to 'break' in the middle which drastically reduces the risk of over-torque
- Dual scale in N-m/ft.lb
- Removable square drive allows torque application clockwise and anticlockwise
- Accurate to  $\pm 4\%$  of reading
- Breaking system triggers a visual and tactile signal
- Delivered in two parts for when storage space is limited such as vehicle tool kits
- Scale is laser etched at 2 ends of the 2 hex bars at the end of the handle
- All in a portable sturdy blow mould case
- Supplied with a factory declaration of conformity according to ISO 6789-1:2017
- Made in the UK

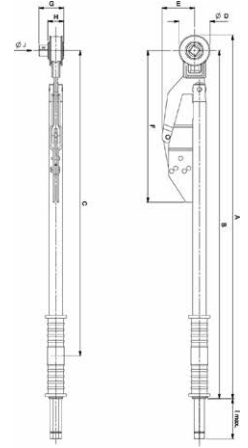

									A	B	C	D	E	F	H	I max	J	
				Nm	ft-lb	in	Nm	ft-lb	mm	mm	mm	mm	mm	mm	mm	mm	mm	
76R1-2000	0522378	1	900-2000	700-1500	1"	50	50	1855	1820	1773	69	75	1379	35	85	38	12.75	

**TAH74R-1500**

*Adjustable Breaking Torque Wrench for Use at Height*



- Large dual scale in N-m and ft-lb
- Unique profiled mechanism gives much clearer "torque break point" reducing the possibility of over torquing
- Robust construction gives accurate results to  $\pm 4\%$  even in arduous working conditions
- Easy to set accurately
- Fixed double sided  $\frac{3}{4}$ " square drive ratchet allows two direction torquing
- Can be split and packed in two parts for smaller, easier to transport package
- Designed to be cost effectively serviced
- Delivered in a plastic gun case which is foam lined
- Supplied with a factory declaration of conformity according to ISO 6789-1:2017
- Made in UK
- Hole in the handle and eyebolt connection for attachment, suitable for working at height
- Always tether the wrench from both attachment points at the same time. Never use just one tethering point.
- Conforms to DROPS best practices

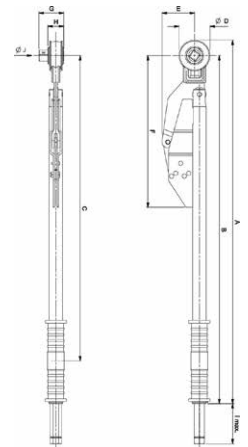

									A	B	C	D	E	F	H	I max	J	
				Nm	ft-lb	in	Nm	ft-lb	mm	mm	mm	mm	mm	mm	mm	mm	mm	
TAH74R-1500	0543144	1	700-1500	500-1000	3/4"	25	25	1764	1730	1635	69	75	1379	35	105	38	9.6	



# DIAL WRENCHES

*All Metal Dial Scale Torque Wrench with Fixed Square Drive, Memory Needle and Free Hand Point Feature*

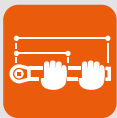
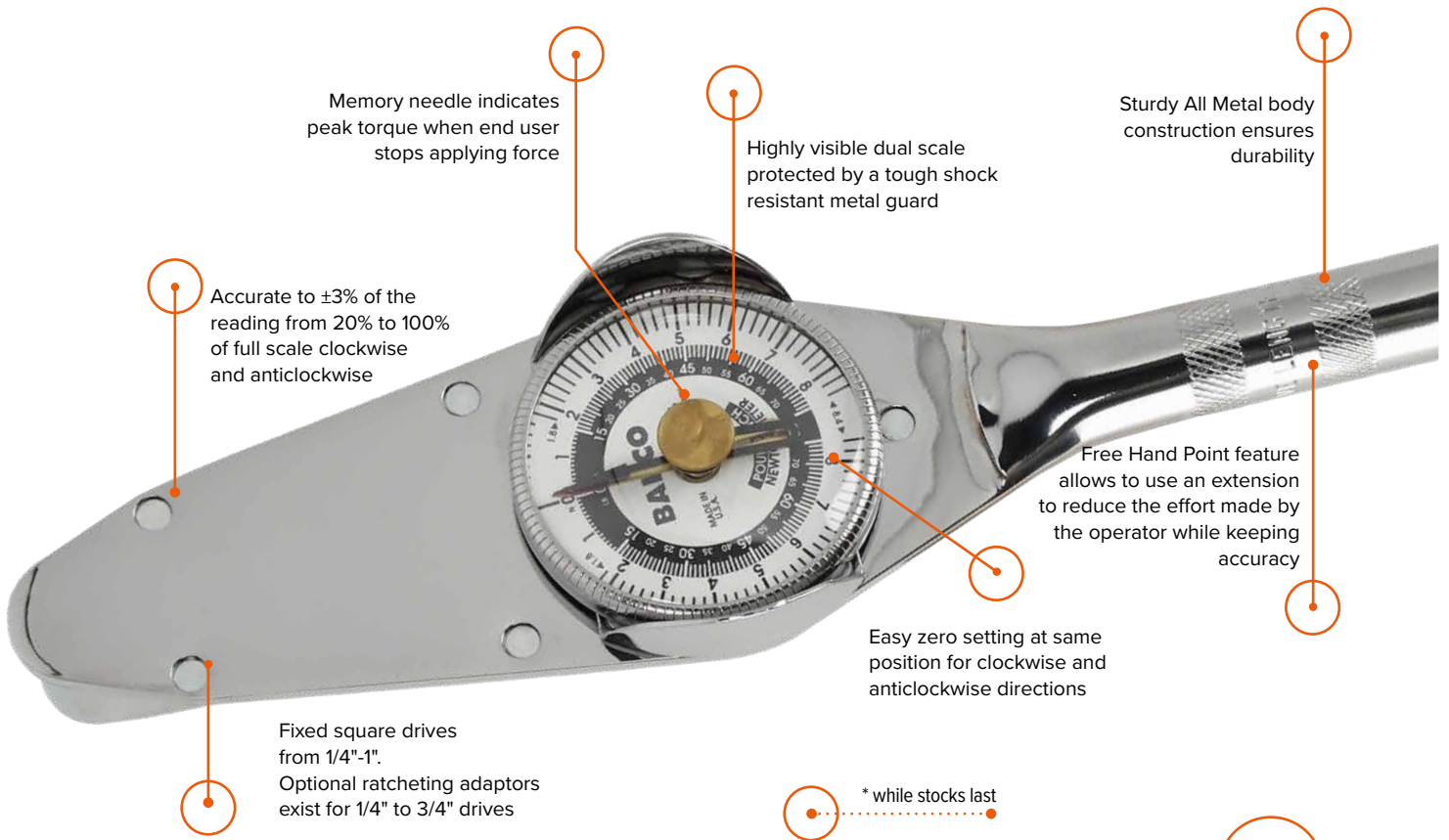

Free-hand point or non-length-dependent feature.



Continuous visual signal with slave pointer showing max torque achieved.



Accuracy  $\pm 3\%$  Clockwise. Anticlockwise.



Dial torque reading wrench to know the torque being applied at every moment



Dual scale in N-m/lb.in or N-m/ft.lb.



Fixed square drive



Declaration of conformity comes with the product.

\* while stocks last

**7454 M**

**All metal Dial Scale Torque Wrench with Fixed Square Drive, Memory Needle and Free Hand Point Feature**



- Sturdy All Metal body construction ensures durability
- Easy to read Dual scale in N-m and imperial units
- Dial is protected by a tough shock resistant metal guard
- Accurate to  $\pm 3\%$  of the reading from 20% to 100% of full scale clockwise and anticlockwise
- Memory needle retains highest torque reading attained
- Torque measurement is not affected by the hand-hold position on the wrench
- Delivered in sturdy blow mould case with a declaration of conformity
- Meets or Exceeds the following Specifications: GGG-W-686C, ANSI B107.14M
- Made in USA

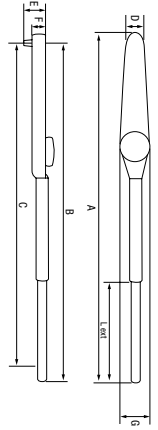

\* while stocks last

				Nm	in-lb	ft-lb		Nm	in-lb	ft-lb	A mm	B mm	C mm	D mm	E mm	F mm	G mm	kg
7454-3.5	0509478	1	0.7-3.5	6-30	-	1/4	0.1	1	-	252	203	203	60	39	31	69	0.5	
7454-8.4	0509485	1	1.68-8.4	15-75	-	1/4	0.2	1	-	252	203	203	60	39	31	69	0.5	
7454-17	0509492	1	3.4-17	30-150	-	3/8	0.5	5	-	252	203	203	60	39	31	69	0.51	
7454-32	0509508	1	6.4-32	60-300	-	3/8	0.5	5	-	252	203	203	60	42	31	69	0.51	
7454-70A	0509577	1	14-70	-	10-50	3/8	1	-	1	318	254	254	60	42	31	69	0.55	
7454-140A	0509515	1	28-140	-	20-100	1/2	5	-	2	398	330	330	69	51	35	69	1.15	
7454-230	0509522	1	46-230	-	35-175	1/2	10	-	5	474	406	406	69	53	38	69	1.26	
7454-800A	0509584	1	160-800	-	120-600	-	20	-	20	1015	991	915	92	68	46	79	3.45	

**7454-480**

**Dial Scale Torque Wrench with Fixed Square Drive and Memory Needle**



- Torque is displayed at every moment during the torque event
- Anti-shock protected dial with dual scales in N-m/ft.lb
- Torque range covers from 100 to 800 N-m and from 70 to 600 ft.lb values
- Can be used CW and ACW by turning the dial and slave pointer to the correct position
- Controlled torque application events to  $\pm 4\%$
- Continuous visual signal with slave pointer showing max torque achieved
- 3/4" fixed square drive across the range
- Metal handle on all models
- Delivered in sturdy blow mould or metal cases
- Supplied with a declaration of conformity in compliance with International Standards
- ISO 6789
- Made in USA

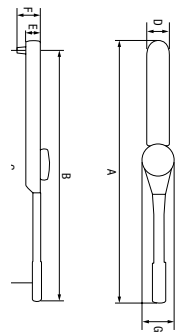

\* while stocks last

				Nm	ft-lb		Nm	ft-lb	A mm	B mm	C mm	D mm	E mm	F mm	G mm	kg
7454-480	0119578	1	100-480	70-350	3/4	10	10	711	680	630	57	70	38	72	2.6	

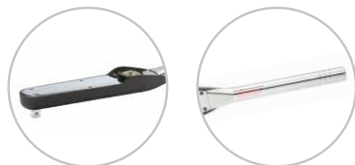



**7454-1400**

**Dial Scale Torque Wrench with Fixed Square Drive, Memory Needle and 2 Sections Handle**



- Torque is displayed at every moment during the torque event
- Anti-shock protected dial with dual scales in N-m/ft.lb
- Can be used CW and ACW by turning the dial and slave pointer to the correct position
- Controlled torque application events to  $\pm 4\%$
- Continuous visual signal with slave pointer showing max torque achieved
- 1" fixed square drive
- Delivered in two pieces which need to be assembled for use and calibration
- Delivered in a sturdy metal case with foam
- Supplied with a declaration of conformity in compliance with International Standards
- ISO 6789
- Made in USA

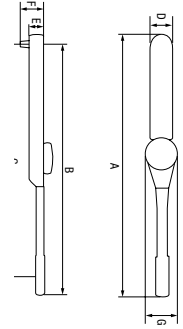

\* while stocks last

									A	B	C	D	E	F	G	
		731415		Nm	ft-lb	in	Nm	ft-lb	mm	mm	mm	mm	mm	mm	mm	
7454-1400	0119592		1	275-1400	200-1000	1	25	20	1880	1790	1740	64	85	50	76	13.62



# PRESET CLICK WRENCHES

## Mechanical Preset Torque Click Wrench with Fixed Ratchet Head

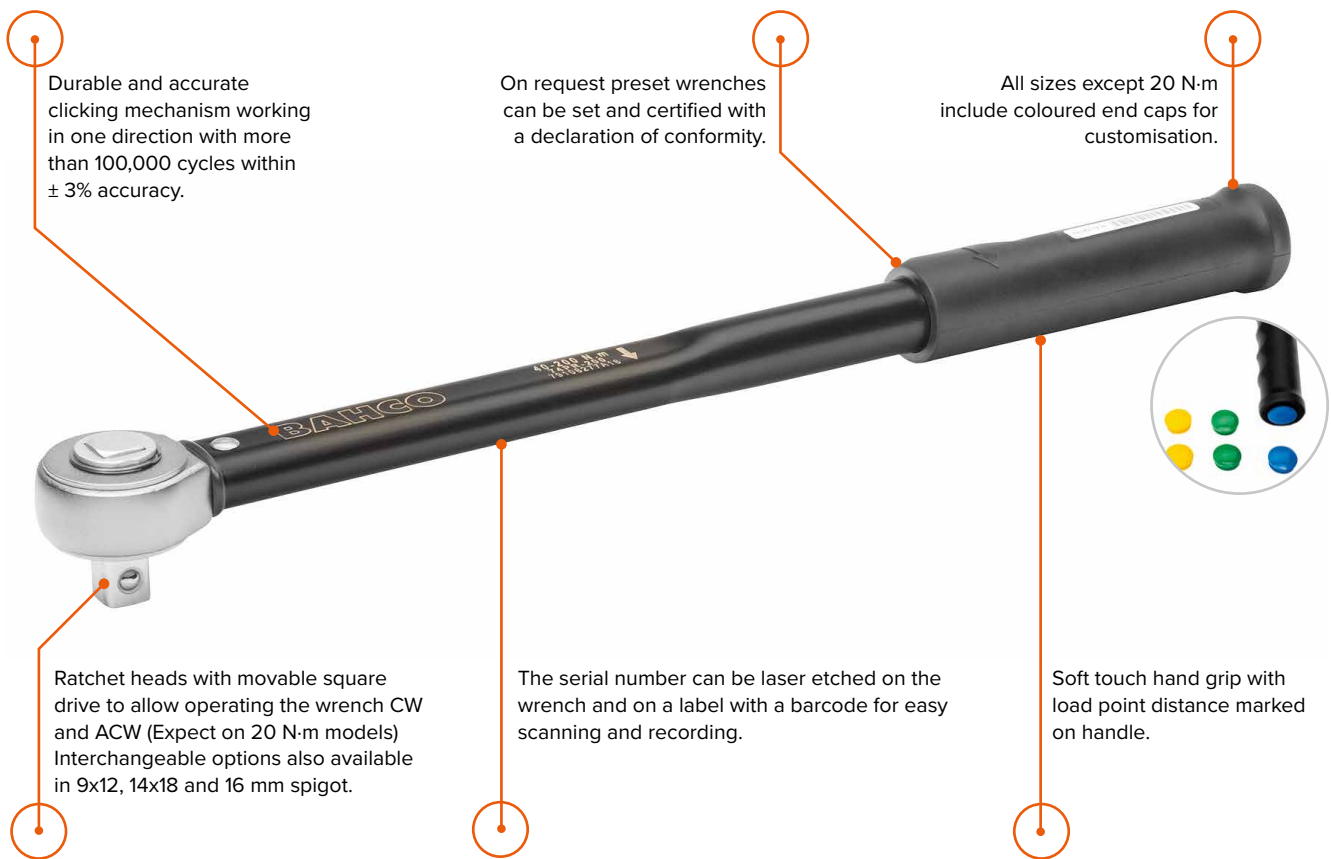

Durable and accurate clicking mechanism working in one direction with more than 100,000 cycles within  $\pm 3\%$  accuracy.

On request preset wrenches can be set and certified with a declaration of conformity.

All sizes except 20 N-m include coloured end caps for customisation.

Ratchet heads with movable square drive to allow operating the wrench CW and ACW (Except on 20 N-m models) Interchangeable options also available in 9x12, 14x18 and 16 mm spigot.

The serial number can be laser etched on the wrench and on a label with a barcode for easy scanning and recording.

Soft touch hand grip with load point distance marked on handle.



Round reversible ratchet head – 20 N-m sizes (74PR-20).



Rectangular female type interchangeable head in 9x12 and 14x18 – from 15 N-m up to 400 N-m.



Movable square drive ratchet head – on all other 74WR sizes up to 400 N-m.



Spigot male interchangeable head in 16 mm – from 15 N-m up to 300 N-m.



Audible click warning to stop applying torque.



Sensitive click warning to stop applying torque.



Accuracy  $\pm 3\%$  Clockwise. Anticlockwise.



Full range on portable blow mould cases.



### 74PR-20

#### Preset Torque Click Wrench with Fixed Ratchet Head



- Over 100,000 cycles within accuracy
- Range covering from 4 to 20 N-m/40 - 180 in.lb torque values
- Can only be used clockwise
- Accurate to  $\pm 3\%$  of reading which exceeds the requirements of ISO6789-1:2017
- Clicking system triggers a tactile and audible signal
- Reversible round ratchet head in 1/4" square drive allowing CW operation only
- In a semi-transparent square tube with eurohole hanger
- On request preset wrenches can be set and certified with a declaration of conformity
- ISO 6789
- Made in the UK

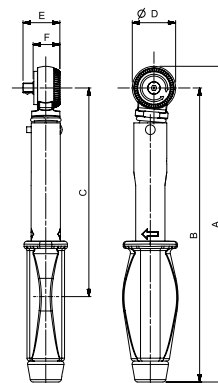

Icon	FAN 731415	Icon	Nm	in	A mm	B mm	C mm	D mm	E mm	F mm	kg
74PR-20	0416158	1	4-20	1/4	219	204	146	30	26	19	400

### 74PR-60/74PR-400

#### Preset Torque Click Wrench with Fixed Push-Through Ratchet Head



- Over 100,000 cycles within accuracy
- Range covering from 12 and 400 N-m/5 - 300 ft.lb torque values
- Can be used clockwise or anticlockwise by pushing across the square drive of the ratchet head
- Accurate to  $\pm 3\%$  of reading which exceeds the requirements of ISO6789-1:2017
- Clicking system triggers a tactile and audible signal
- Push-through ratchet heads from 3/8" to 1/2" square drives allowing CW and ACW operations
- Colour-coded adjustment seals and locking tool provided
- In a semi-transparent square tube with eurohole hanger
- On request preset wrenches can be set and certified with a declaration of conformity
- ISO 6789
- Made in the UK

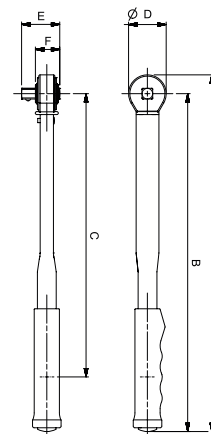

Icon	FAN 731415	Icon	Nm	in	A mm	B mm	C mm	D mm	E mm	F mm	kg
74PR-60	0416165	1	12-60	3/8	295	277	212	36	34	21	0.600
74PR-60A	0416172	1	12-60	1/2	301	281	216	42	38	23	0.700
74PR-100	0416189	1	20-100	3/8	335	317	252	36	34	21	0.700
74PR-100A	0416196	1	20-100	1/2	342	321	256	42	38	22	0.700
74PR-200	0416202	1	40-200	1/2	425	403	338	45	46	29	1.000
74PR-300	0416219	1	60-300	1/2	668	641	577	54	46	29	1.200
74PR-400	0416226	1	80-400	3/4	675	649	584	52	51	28	2.000





**74P9-20**

**Preset Torque Click Wrench  
with Interchangeable Head and Plastic Handle**



- Over 100,000 cycles within accuracy
- Range covering from 4 to 20 N-m/40 - 180 in.lb torque values
- Can be used clockwise or anticlockwise by turning the wrench over
- Accurate to  $\pm 3\%$  of reading which exceeds the requirements of ISO6789-1:2017
- Clicking system triggers a tactile and audible signal
- 9x12 rectangular female interchangeable head allowing CW and ACW operations
- In a semi-transparent square tube with eurohole hanger
- On request preset wrenches can be set and certified with a declaration of conformity
- ISO 6789
- Made in the UK

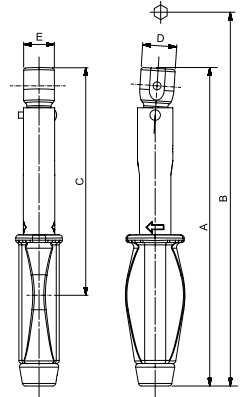

					A	B	C	D	E	
	731415		Nm	mm	mm	mm	mm	mm	mm	
74P9-20	0416288	1	4-20	9x12	205	223	146	22	20	0.400



**74P9-60/74P14-400**

**Preset Torque Click Wrench  
with Interchangeable Head and Rubber Handle**



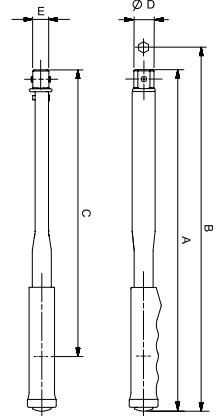

- Over 100,000 cycles within accuracy
- Range covering from 12 and 400 N-m/5 - 300 ft.lb torque values
- Can be used clockwise or anticlockwise by turning the wrench over
- Accurate to  $\pm 3\%$  of reading which exceeds the requirements of ISO6789-1:2017
- Clicking system triggers a tactile and audible signal
- 9x12 and 14x18 rectangular female interchangeable heads allowing CW and ACW operations
- Colour-coded adjustment seals and locking tool provided
- In a semi-transparent square tube with eurohole hanger
- On request preset wrenches can be set and certified with a declaration of conformity
- ISO 6789
- Made in the UK



					A	B	C	D	E	
	731415		Nm	mm	mm	mm	mm	mm	mm	
74P9-60	0416295	1	12-60	9x12	286	304	222	22	20	0.600
74P9-100	0416301	1	20-100	9x12	326	344	262	22	20	0.600
74P14-200	0416318	1	40-200	14x18	403	428	338	25	20	0.800
74P14-300	0416325	1	60-300	14x18	534	559	469	36	28	1.100
74P14-400	0416332	1	80-400	14x18	652	677	588	32	24	1.800

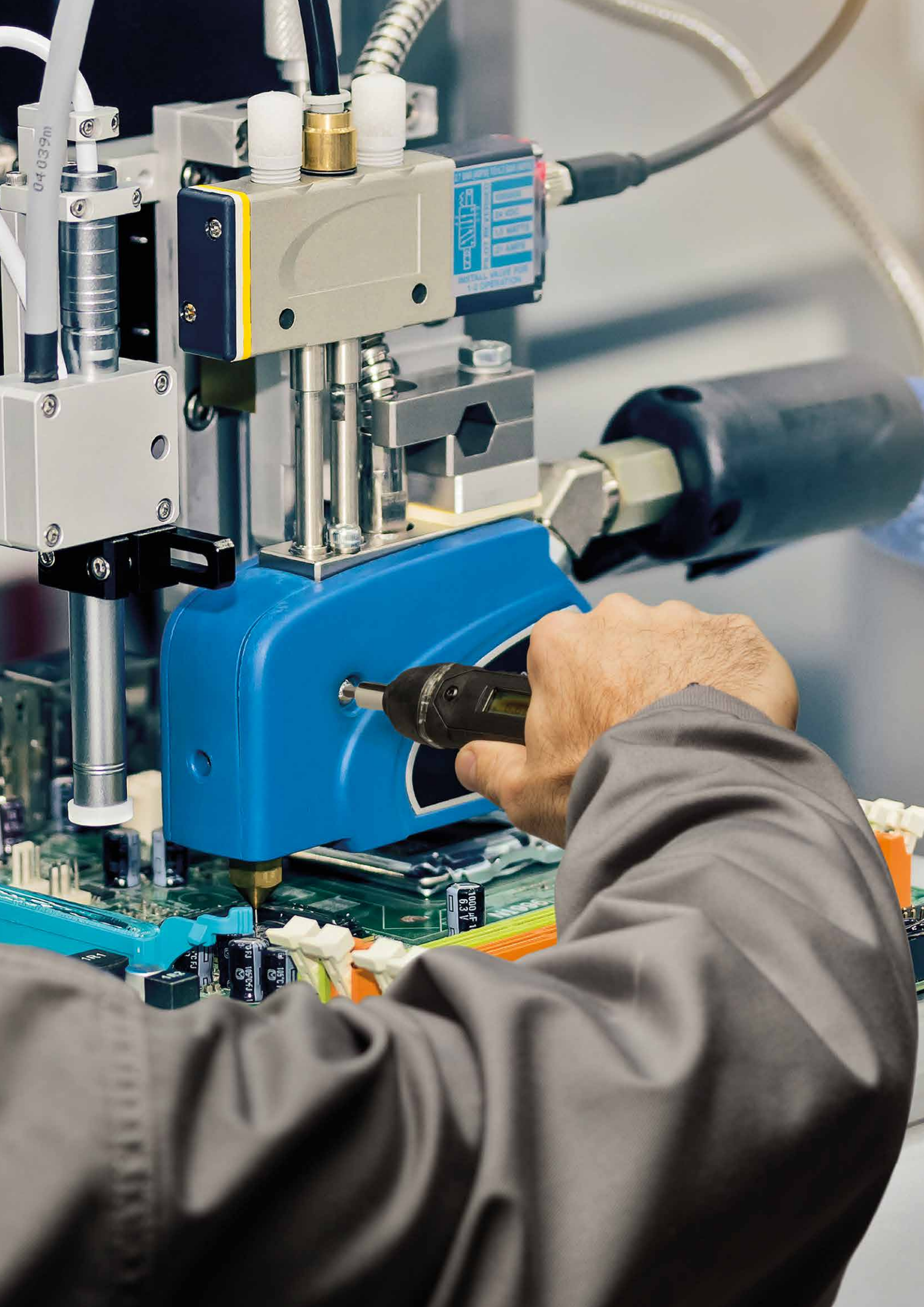





Bahco's digital and mechanical torque screwdrivers are ideal for the highest requirements, such as accuracy, precision, speed of use, data record and transfer and preventing over-torque. One torque screwdriver does the job of multiple torque screwdrivers. They are easy to use, easy to set and easy to recalibrate.

Production line managers, quality control technicians and laboratory calibration technicians will benefit from using the digital torque screwdrivers to improve productivity, traceability, facilitate calibration and for better control.

Ease and comfort in use. To be used for mechanical and electrical work. Easy to adjust, easy to use on small things. It includes a range that is ESD safe for electronics within the adjustable and preset screwdrivers. Allows you to precisely limit the amount of torque for any application.

# ***DIGITAL AND MECHANICAL TORQUE SCREWDRIVERS***

- *Bluetooth® Torque Angle Screwdrivers*
- *USB Torque Angle Screwdrivers*
- *Digital Torque Angle Screwdrivers*
- *Adjustable Screwdrivers with Scale*
- *Preset Screwdrivers*
- *Fixed Preset Screwdrivers*
- *Fixed Preset Screwdriver Blades*

# BLUETOOTH® TORQUE ANGLE SCREWDRIVERS

Digital Torque and Angle Screwdrivers with Bluetooth®



Range	CW	ACW
20% to 100%	±2%	±3%
5% to 19%	±4%	±6%



Bluetooth® real time connectivity to PC or tablet



Digital torque reading to know the torque being applied at every moment. Multiple units of measurement



Bahco Connect App available for Windows 10, iOS and Android at the different stores.



Female hexagonal drive



Audible beep warning to stop applying force when reaching target torque.



Sensitive vibration warning to stop applying force when reaching target torque.



Visual warnings: Progressive yellow LED light indicating 40%, 60%, 80% of target torque achieved. Green LED light indicating target torque achieved. Red LED indicating over-torque.



Declaration of conformity comes with the product.



Full range in a hanging colour box, fabric pouch and foam inlay.



Accuracy between 20 and 100% of full scale. (see table)



**TASMB14H**  
*Digital Torque and Angle Bluetooth® Screwdriver*



- Bluetooth® real-time 2-way data transfer
- Bahco Connect free app available for Windows 10, Android and iOS in 18 languages
- Easy to set up and use
- Recalibration warning by time and/or number of cycles
- Re-Do option
- Data download through Bahco Connect app
- Torque units in Newton.metre, kg.cm, dNewton.metre, ft.lb, lb.in (cNewton.metre & in.oz depending on range), and angle units in degrees
- Can be used CW and CCW at temperatures between 5°C and 42°C
- Memory capacity for 1500 readings and up to 50 presets
- Torque, angle, torque and angle, torque then angle, preset and job modes
- Counter
- Data and set value retention during battery exchange
- Programmable automatic shut-off time
- More advanced configurations and settings available in user manual
- Accurate to ±2% CW - 3% CCW between 20% and 100% of max torque
- Accurate to ±6% CW and CCW between 5% and 19% of full scale
- Visual (360 degree viewable LED lights + backlit LCD display), audible and vibration signal
- 1/4" hex female drive with strong magnetic retention
- Durable composite tri-lobe hinge body for better control
- Low profile recessed membrane keypad with button lockout to avoid unintended target torque change when operating the screwdriver
- Battery cap for single AA alkaline Battery (included)
- Composite L-handle grip attachment (std on 9 N-m model) gives the user more leverage and control when applying torque and/or angle in the higher torque ranges
- All in a semi-transparent square tube with eurohole hanger
- Supplied with a declaration of conformity according to ISO 6789-1:2017 traceable to International standards
- CE and UKCA marked
- Made in USA

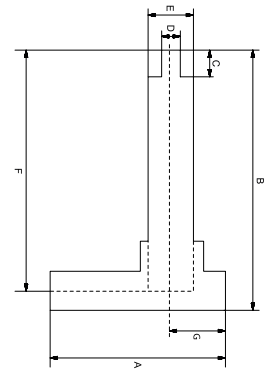

										A	B	C	D	E	F	G	
	731415			Nm	cN-M	in-lb	in-oz			mm	mm	mm	mm	mm	mm	mm	kg
TASMB14H007	0489664	1	0.04-0.7	3.5-70	3.1-61.9	4.95-99	-	1/4"	130	226	12	11	32	189	40	0.325	
TASMB14H09	0489671	1	0.45-9	45-900	4-80	64-1280	-	1/4"	130	226	12	11	32	189	40	0.325	



To know more about Bahco Connect App, go to **page 10**

# USB TORQUE ANGLE SCREWDRIVERS

*Digital Torque and Angle Screwdrivers with USB*

1/4" Hex Female Drive with Earth Magnet Retention.

Plug & Play connectivity to PC through USB

50 Preset & 1500 Data Storage

Low Profile Recessed Membrane Keypad with Button Lockout.

Durable Composite Tri-Lobe Hing Grip for better control.

Buzzer

Vibration Handle Alert.

3/8" Threaded Slotted Battery Cap. Single AA Alkaline Battery.

Composite L-Handle Grip Attachment Provides Operator more leverage and control when applying torque and or angle in the higher torque ranges.

360 Degree Visual Timed LED Progression

Seven Languages: English, French, Spanish, German, Italian, Nederlands, Portuguese

Modes of Operation: Torque, Angle, Torque Then Angle, Torque and angle, Job Mode.

Units of Measure: In-lb, In-oz, ft-lb, Nm, kg-cm, cNm

Range	CW	ACW
20% to 100%	±2%	±3%
5% to 19%	±4%	±6%



Plug and play data download to Excel through cable with USB connection



Digital torque reading to know the torque being applied at every moment.  
Multiple units of measurement



Female hexagonal drive



Audible beep warning to stop applying force when reaching target torque.



Sensitive vibration warning to stop applying force when reaching target torque.



Visual warnings: Progressive yellow LED light indicating 40%, 60%, 80% of target torque achieved. Green LED light indicating target torque achieved. Red LED indicating over-torque.



Declaration of conformity comes with the product.



Full range in a hanging colour box, fabric pouch and foam inlay.



Accuracy between 20 and 100% of full scale. (see table)



**TASM14H**

*Digital Torque and Angle Screwdriver with Memory and USB*



- Plug & Play USB data download to excel format
- Easy and intuitive to use
- Torque Units in Newton Meter, kg.cm, dNewton Meter, ft.lb, lb.in (cNewton Meter & in.oz depending on range) and Angle units in degrees
- It can be used CW and CCW at temperatures between 5°C and 42°C
- Memory capacity of 1500 readings and up to 50 presets
- Torque, Angle, Torque and Angle, Torque then angle, preset and job modes
- Cycle Counter
- Data and set value retention during battery exchange
- Programmable automatic shut-off time
- More advanced configurations and settings available in user manual
- Accurate to  $\pm 2\%$  CW - 3% CCW between 20% and 100% of max torque
- Accurate to  $\pm 6\%$  CW and CCW between 5% and 19% of full scale
- Visual (360 degree viewable LED lights + backlit LCD display), audible and vibration signal
- 1/4" Hex Female Drive with Earth Magnet Retention
- Durable Composite Tri-Lobe Hinge body for better control
- Low Profile Recessed Membrane Keypad with Button Lockout to avoid unintended target torque change when operating the screwdriver
- Battery Cap for Single AA Alkaline Battery (included)
- Composite L-Handle Grip Attachment (std on 9 N-m model) provides operator more leverage and control when applying torque and or angle in the higher torque ranges
- All in semi-transparent square tube with eurohole hanger
- Supplied with a factory declaration of conformity and CE marking
- Made in USA

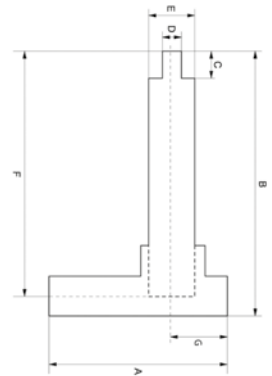

									A	B	C	D	E	F	G	
		731415		Nm	cN-M	in-lb	in-oz		mm	mm	mm	mm	mm	mm	mm	
TASM14H09	0539437		1	0.45-9	45-900	4-80	64-1280	1/4"	130	226	12	11	32	189	40	0.325
TASM14H007	0539444		1	0.035-0.700	3.5-70	3.1-61.9	4.95-99	1/4"	130	226	12	11	32	189	40	0.325

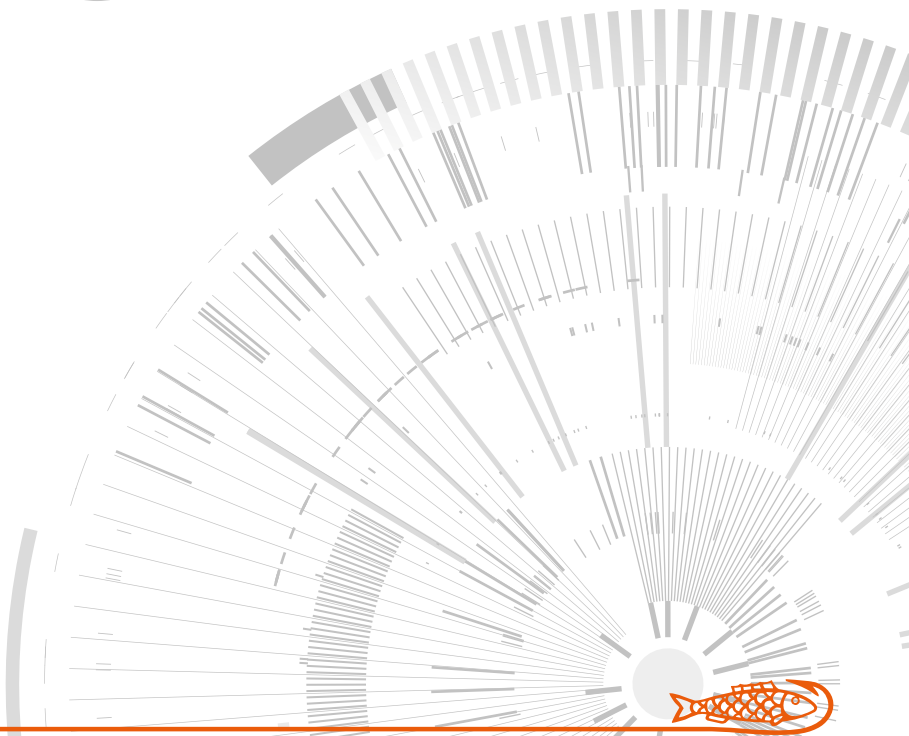

# DIGITAL TORQUE ANGLE SCREWDRIVERS

## Digital Torque and Angle Screwdrivers

1/4" Hex Female Drive with Earth Magnet Retention. Also available in 1/4" Square Male drive.

Durable Composite Tri-Lobe Hing Grip for better control.

Low Profile Recessed Membrane Keypad with Button Lockout.

Vibration Handle Alert.

10 Target Preset Values and 50 Data Records

3/8" Threaded Slotted Battery Cap. Single AA Alkaline Battery.

Audible Beep. Seven Languages: English, French, Spanish, German, Italian, Dutch, Portuguese  
Modes of Operation: Torque, Angle, Torque Then Angle, Units of Measurement: In-lb, In-oz, ft-lb, N-m, kg-cm, cN-m

360 Degree Visual Timed LED Progression

Composite L-Handle Grip Attachment provides the operator with more leverage and control when applying torque and/or angle in the higher torque ranges.

Range	CW	ACW
20% to 100%	±2%	±3%
5% to 19%	±4%	±6%



Digital torque reading to know the torque being applied at every moment.



Visual warnings: Progressive yellow LED light indicating 40%, 60%, 80% of target torque achieved. Green LED light indicating target torque achieved. Red LED indicating over-torque.



Audible beep warning to stop applying force when reaching target torque.



Sensitive vibration warning to stop applying force when reaching target torque.



Declaration of conformity comes with the product.



Multiple units of measurement.



Accuracy between 20 and 100% of full scale. (see table)



**TAS14**  
*Digital Torque Screwdriver*



- Torque units in N-m, kg.cm, cN-m, ft.lb, in.lb, in.oz and angle units in degrees
- Can be used CW and ACW
- Accurate to  $\pm 2\%$  CW and  $\pm 3\%$  ACW between 20% and 100% of max torque
- Visual (360 degree viewable LED lights + backlit LCD display), audible and vibration signal
- 1/4" Female hex drive with earth magnet retention or 1/4" male square drive
- Durable Composite Tri-Lobe Hinge body for better control
- Low Profile Recessed Membrane Keypad with Button Lockout to avoid unintended target torque change when operating the screwdriver
- Battery Cap for Single AA Alkaline Battery (included)
- Composite L-Handle Grip Attachment (std on 9 N-m models) Provides Operator more leverage and control when applying torque and or angle in the higher torque ranges
- In a semi-transparent square tube with eurohole hanger
- Supplied with a factory declaration of conformity and CE marking
- Made in USA

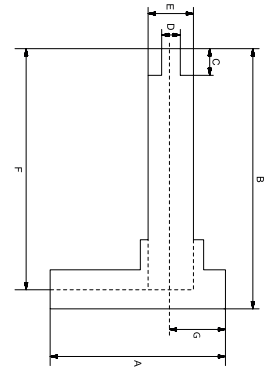

										A	B	C	D	E	F	G	
		731415		Nm	cN-M	in-lb	in-oz			mm	mm	mm	mm	mm	mm	mm	
TAS14H007	0423187	1	0.04-0.7	3.5-70	3.1-61.9	4.95-99		1/4"		130	226	12	11	32	189	40	0.325
TAS14S007	0423194	1	0.04-0.7	3.5-70	3.1-61.9	-	1/4"			130	226	12	1/4"	32	189	40	0.325
TAS14H09	0423200	1	0.45-9	45-900	4-80	64-1280	-	1/4"		130	226	12	11	32	189	40	0.325
TAS14S09	0423217	1	0.45-9	45-900	4-80	64-1280	1/4"	-		130	226	12	11	32	189	40	0.325

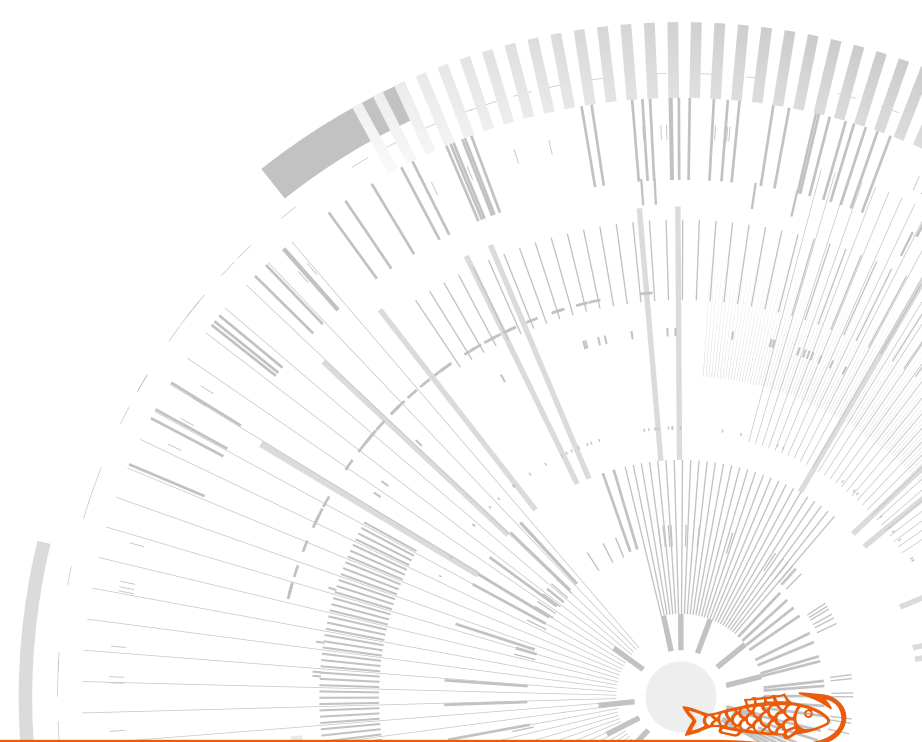

# ADJUSTABLE SCREWDRIVERS WITH SCALE

## Adjustable Torque Screwdriver with Window Scale

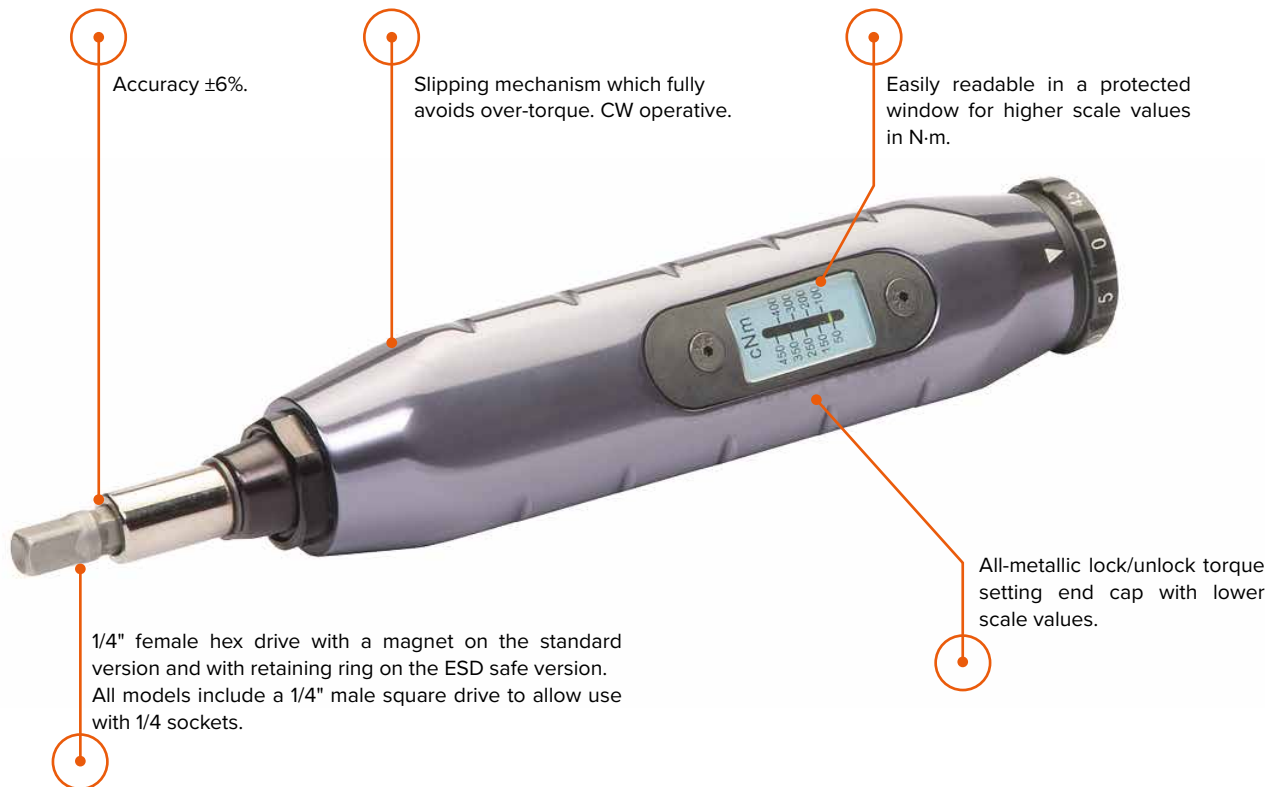

Declaration of conformity comes with the product.



Sensitive click warning to stop applying torque.



Audible click warning to stop applying torque.



Accuracy clockwise ±6%.



**6973N-6978N**

*Adjustable Torque Screwdriver with Window Scale*



- Over-torque limiting clutch
- Single scale in cN-m
- Range covering between 10 and 450 cN-m torque values
- Torque measurement clockwise only. It can be used to loosen fasteners without affecting the internal mechanism
- ±6% CW
- Clicking system triggers a tactile and audible signal
- ¼" hex magnet bit holder. Includes a ¼" adaptor for sockets
- All-metal three-lobe handle
- Supplied in an adjustable semi-transparent square tube
- Supplied with a factory declaration of conformity in compliance with International Standards
- ISO 6789
- Made in USA

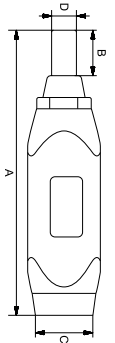

							A	B	C	D	
			cN-M	in	in	cN-M	mm	mm	mm	mm	
6973N	1845605	1	16-80	1/4	1/4	1	150	18,2	32	9,6	0.210
6976N	1845612	1	40-200	1/4	1/4	2	160	18,2	32	9,6	0.260
6978N	1845629	1	90-450	1/4	1/4	5	170	18,2	31	9,6	0.300

**MA500-1 - MA500-3**

*Adjustable Torque Screwdriver with Window Scale and ESD Safe*



- ESD safe (IEC 61340-5-1)
- Over-torque limiting clutch
- Single scale in cN-m
- Range covering between 10 and 450 cN-m torque values
- Torque measurement clockwise only. It can be used to loosen fasteners without affecting the internal mechanism
- Accurate to ±6% CW
- Clicking system triggers a tactile and audible signal
- ¼" hex non-magnetic spring-loaded bit holder to avoid damaging sensitive equipment or components in electronic applications
- All-metal three-lobe handle
- Supplied in an adjustable semi-transparent square tube
- Supplied with a factory declaration of conformity
- ISO 6789, IEC61340-5-1
- Made in USA

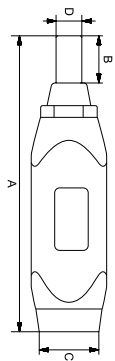

						A	B	C	D	
			cN-M	in	cN-M	mm	mm	mm	mm	
MA500-1A	0458882	1	16-80	1/4	1	138	18.2	28	9.6	0.200
MA500-2A	0458899	1	40-200	1/4	2	157	18.2	28	9.6	0.260
MA500-3A	0456925	1	90-450	1/4	5	171	18.2	32	9.6	0.308





### TSS120

#### Adjustable Torque Screwdriver with Marked Scale in cN·m



- Over-torque limiting clutch
- Single scale in cN·m
- Torque measurement clockwise only
- Accurate to  $\pm 6\%$  CW
- Clicking system triggers a tactile and audible signal
- $\frac{1}{4}$ " square drive
- Three-lobe rubber handle
- Supplied in an adjustable semi-transparent square tube
- Supplied with a factory declaration of conformity
- ISO 6789

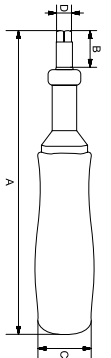

						A	B	C	D	
TSS120	731415	1	cN·M	in	cN·M	mm	mm	mm	mm	kg
	0347063		10-120	1/4	1	175	18,2	35	9,6	0.230



### TSS600

#### Adjustable Torque Screwdriver with Marked Scale in N·m



- Over-torque limiting clutch
- Dual scale in N·m and in.lb
- Torque measurement clockwise only.
- Accurate to  $\pm 6\%$  CW
- Clicking system triggers a tactile and audible signal
- $\frac{1}{4}$ " square drive
- Three-lobe rubber handle with additional female square to hold a  $\frac{1}{4}$ " sliding T handle
- Supplied in an adjustable semi-transparent square tube
- Supplied with a factory declaration of conformity
- ISO 6789

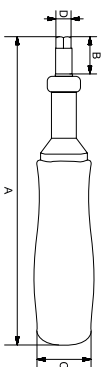

						A	B	C	D	
TSS600	731415	1	Nm	in	cN·M	mm	mm	mm	mm	kg
	0346417		1-6	1/4	0.1	195	18,2	35	9,6	0.340



**6852-5**

*Adjustable Torque Mini Wrench with Fixed Screwdriver Bit*



- Non-length-dependent. It remains accurate regardless of hand position
- Single scale in N-m is protected inside the handle
- Bits can be inserted from both sides of the tool which allows CW and ACW operations
- Controlled torque application events to  $\pm 6\%$
- Clicking system triggers a tactile and audible signal
- $\frac{1}{4}$ " hex bit fixed holder offers the convenience of interchangeable ISO 1173 Form C drive bits
- Light and compact to allow working in confined spaces
- Delivered in a plastic box with foam protection and further space for bits and accessories
- Supplied with a factory declaration of conformity
- ISO 6789
- Made in the UK

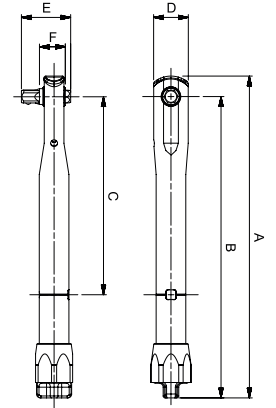

						A	B	C	D	E	F	
6852-5	731415	1	Nm	in	Nm	mm	mm	mm	mm	mm	mm	kg
6852-5	0125463	1	1-5	1/4	0.1	170	160	121,5	17	25	10	0.100



**6852-5/S17**

*Adjustable Torque Mini Wrench Set with Fixed Screwdriver Bit*

- Torque tool set, 17 pcs

6852-5/S17	731415	1	kg
6852-5/S17	0135875	1	3.295



**52H**  
PH0, PH1



**51PZDSDVH**  
PZ0, PZ1



**64TORX**  
T-5, T-6, T-7, T-8



**55M**  
1.5, 2.0, 2.5



**50K**  
0.6x4.5, 0.8x5.5



**6700SM**  
4mm



**KM653-QR**



**6852-5**



### 6876N-6880N Preset Torque Screwdriver



- Over-torque limiting clutch
- Range covering between 4 and 450 cN-m torque values
- Torque measurement clockwise only. It can be used to loosen fasteners without affecting the internal mechanism
- Clicking system triggers a tactile and audible signal
- ¼" hex magnet bit holder. Includes a ¼" adaptor for sockets
- All-metal three-lobe handle
- Accurate to ±6% CW
- Supplied in an adjustable semi-transparent square tube
- On request preset screwdrivers can be set and certified with a declaration of conformity in compliance with International Standards
- ISO 6789
- Made in USA

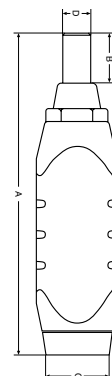

			 cN-M	 in	 in	A mm	B mm	C mm	D mm	
6876N	1845575	1	7-70	1/4	1/4	145	18,2	30	9,6	0.200
6878N	1845582	1	15-170	1/4	1/4	155	18,2	30	9,6	0.220
6880N	1845599	1	45-450	1/4	1/4	170	18,2	31	9,6	0.280



### PS501 Preset Torque Screwdriver ESD Safe



- ESD safe (IEC 61340-5-1)
- Over-torque limiting clutch
- Range covering between 4 and 450 cN-m torque values
- Torque measurement clockwise only. It can be used to loosen fasteners without affecting the internal mechanism
- Clicking system triggers a tactile and audible signal
- ¼" hex non-magnetic spring-loaded bit holder to avoid damaging sensitive equipment or components in electronic applications
- All-metal three-lobe handle
- ±6% CW
- Supplied in an adjustable semi-transparent square tube
- On request preset screwdrivers can be set and certified with a declaration of conformity in compliance with International Standards
- ISO 6789, IEC61340-5-1
- Made in USA

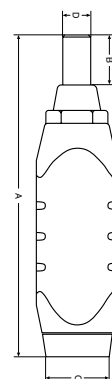

			 cN-M	 in	A mm	B mm	C mm	D mm	
PS501-1	0338283	1	4-22	1/4	115	18.2	28	9.6	0.147
PS501-2	0112432	1	7-70	1/4	141	18.2	28	9.6	0.200
PS501-3	0338290	1	15-170	1/4	141	18.2	28	9.6	0.198
PS501-4	0338306	1	45-450	1/4	154	18.2	32	9.6	0.270



## 6852P-5

### Preset Torque Mini Wrench with Fixed Screwdriver Bit



- Non-length-dependent. It remains accurate regardless of hand position
- Bits can be inserted from both sides of the tool which allows CW and ACW operations
- Controlled torque application events to  $\pm 6\%$
- Clicking system triggers a tactile and audible signal
- $\frac{1}{4}$ " hex bit fixed holder offers the convenience of interchangeable ISO 1173 Form C drive bits
- Light and compact to allow working in confined spaces
- Delivered in a plastic box with foam protection and further space for bits and accessories
- On request preset wrenches can be set and certified with a declaration of conformity in compliance with International Standards
- ISO 6789
- Made in the UK

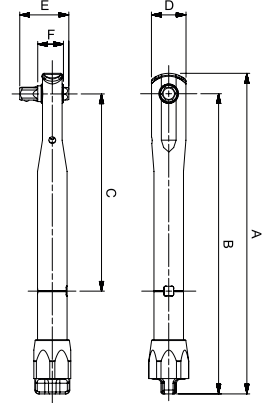

						A	B	C	D	E	F	
		731415		Nm		mm	mm	mm	mm	mm	mm	kg
6852P-5		0416585	1	1-5	$\frac{1}{4}$ "	157	147	102	18	25	13	0.100



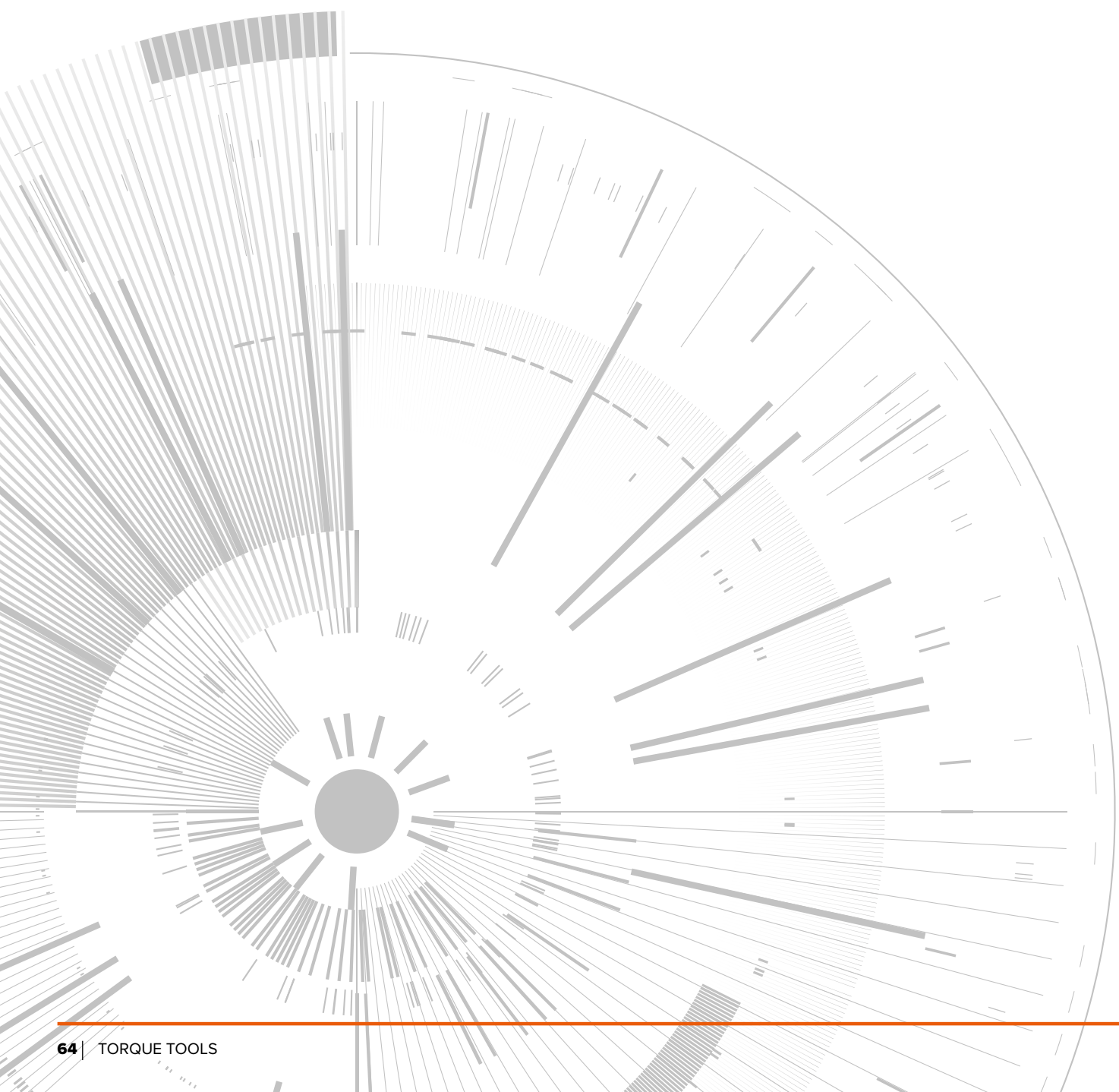

# FIXED PRESET SCREWDRIVERS

## Fixed Preset ERGO™ Torque Screwdriver



Audible click warns the operator that target torque is reached.



Sensitive click warns the operator target torque is reached.



Accuracy  $\pm 10\%$  CW





### BE-6990

#### Fixed Preset ERGO™ Torque Screwdriver



- Torque screwdriver developed according to the scientific ERGOTM process
- Over-torque limiting clutch
- Designed for correct tightening of precision fasteners, for example in CNC machines, at 0.6, 0.9, 1.2, 1.4, 2.0, 3.0 N-m torque values
- Torque measurement clockwise only. It can be used to loosen fasteners without affecting the internal mechanism
- Accuracy  $\pm 10\%$  CW
- Clicking system triggers a tactile and audible signal
- 1/4" hex shank chrome plated and entirely hardened blades with black finish Torx® and Torx® Plus tips for higher dimensional accuracy
- Replaceable blades available
- Supplied in an adjustable semi-transparent square tube
- Made in Europe

BE-6990-IP6	1846725	1	0.6	T6	IP6	55	32	113	168	150
BE-6990-IP7	1846732	1	0.9	T7	IP7	55	32	113	168	130
BE-6990-IP8	1846749	1	1.2	T8	IP8	55	32	113	168	100
BE-6990-IP9	1846756	1	1.4	T9	IP9	55	32	113	178	150
BE-6990-IP10	1846763	1	2	T10	IP10	55	30	113	178	100
BE-6990-IP15	1846770	1	3	T15	IP15	65	32	113	178	150

### BE-6990-IPSET

#### Preset Torque Mini Wrench with Fixed 1/4 Inch Drive



- ERGO™ torque screwdriver set with four torque screwdriver handles, four Torx® blades and four Torx® plus blades in a fabric zip case
- Set includes: BE-6990-IP7, BE-6990-IP8, BE-6990-IP9, BE-6990-IP15



BE-6990-IPSET	3019356	1	0.755	



### BE-6990TX-KL

#### Torque Screwdriver Blades with TORX® Tip



- Replaceable blade for Ergo Torque screwdrivers
- Designed for precision fasteners, for example in CNC machines, with tip sizes T6, T7, T8, T9, T10 and T15
- ¼" hex shank chrome-plated and entirely hardened blades with black finish Torx® tips for higher dimensional accuracy
- Made in Europe

BE-6990TX-T6-KL	1847722	10	T6	1.70	160	40
BE-6990TX-T7-KL	1847739	10	T7	1.99	160	30
BE-6990TX-T8-KL	1847746	10	T8	2.31	160	40
BE-6990TX-T9-KL	1847753	10	T9	2.50	170	40
BE-6990TX-T10-KL	1847760	10	T10	2.74	170	40
BE-6990TX-T15-KL	1847777	10	T15	3.27	170	30



### BE-6990-IP-KL

#### Torque Screwdriver Blades with TORX® PLUS® Tip



- Replaceable blade for Ergo Torque screwdrivers
- Designed for precision fasteners, for example in CNC machines, with tip sizes IP6, IP7, IP8, IP9, IP10 and IP15
- ¼" hex shank chrome-plated and entirely hardened blades with black finish Torx® Plus tips for higher dimensional accuracy
- Made in Europe

BE-6990-IP6-KL	1847494	10	IP6	1.50	170	40
BE-6990-IP7-KL	1847500	10	IP7	1.99	170	40
BE-6990-IP8-KL	1847517	10	IP8	2.31	170	40
BE-6990-IP9-KL	1847524	10	IP9	2.50	170	40
BE-6990-IP10-KL	1847531	10	IP10	2.74	170	40
BE-6990-IP15-KL	1847548	10	IP15	3.27	170	40







Bahco's solution is to use a compact, epicyclical gearbox to accurately multiply the input by a fixed ratio. This fixed ratio might vary between 5:1 and 27:1 depending on the model and size. This allows to use a much smaller torque wrench for a given torque application and the combined weight of the torque multiplier and torque wrench will often be lower than for a single large torque wrench. For the user, it improves productivity for a wider range of applications.

# **MULTIPLIERS**

• *Hand Torque Multipliers*

# HAND TORQUE MULTIPLIERS

## Hand Torque Multiplier with Offset and Straight Reaction Arms



### FOR YOUR SAFETY:

- This tool is intended for use with threaded fasteners. Any other use is not recommended.
- These tools require a reaction bar. See section on torque reaction on the user manual.
- There is a risk of crushing between the reaction bar and work piece.
- Keep hands away from the reaction bar.
- Keep hands away from tool output.
- Bahco recommends looking for a firm reaction point as far as possible from the screw to be fastened or unfastened.

### 89049TM-1000

#### Hand Torque Multiplier with Offset and Straight Reaction Arms

- Max torque output of 1,000 N-m
- Always use with torque wrench (CW and ACW) to avoid exceeding the maximum torque of the multiplier
- Accuracy  $\pm 4\%$
- Small and compact design
- Supplied with straight and offset reaction arms for maximum versatility
- Quick change offset arm with improved flexibility allowing reaction in eight orientations
- Made in the UK

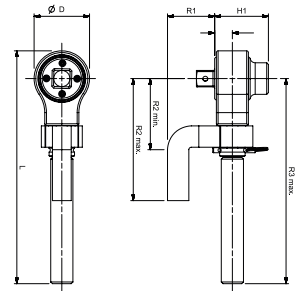

Icon	731415	Qty	MAX N.m	in	5:1	MAX Nm	in	D mm	H1 mm	H2 mm	L mm	R1 mm	R2 min mm	R2 max mm	R3 max mm	kg	kg	
89049TM-1000	0415403	1	1000	3/4	5:1	200	1/2"	65	63	21	273	55	83	143	240	0.5	0.69	2.7



### 8905-TM/9505-TM

#### Hand Torque Multiplier with Offset and Straight Reaction Arms

- Range covers, max output torque up to 2,700 N-m
- Always use with a torque wrench (CW and ACW) to avoid exceeding the maximum torque of the multiplier
- Accuracy  $\pm 4\%$
- Supplied with straight and offset reaction arms
- Supplied in a portable blow mould case
- Made in the UK

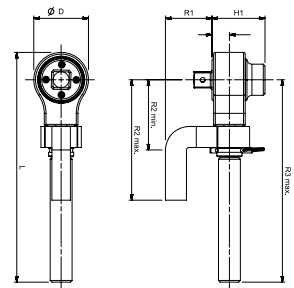

Icon	731415	MAX N.m	in	5:1	MAX Nm	in	D mm	R3 max mm	H1 mm	L mm	R2 max mm	R2 min mm	R1 mm	kg	kg	kg
8905-TM	0125470	1300	3/4	5:1	260	1/2	108	344	103	210	212	140	77	1.36	1.06	3,8
9505-TM	0125487	2700	1	5:1	540	3/4	108	344	100	210	212	140	85	1.36	1.06	3,8





**9505**  
*Hand Torque Multiplier with Reaction Plate*

- Reaction plate with sliding point allows choosing the best reaction point for the job at hand
- The further from the bolt to fasten, the better
- Use always with torque wrench (CW and CCW) to avoid exceeding the maximum torque of the multiplier
- Accuracy ±4%
- Supplied in portable fabric bag
- Made in UK

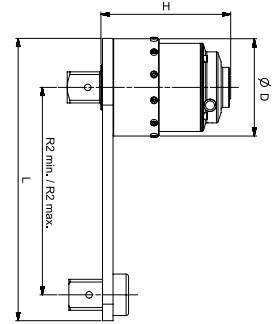

Icon	PAN 731415	Icon	MAX Nm	Icon	Icon	MAX Nm	Icon	D mm	H mm	L mm	R2 min mm	R2 max mm	kg
9505-3400	0125517	1	3400	1	5.2:1	653	3/4	119	106	355	86	263	7.200



**9525/9625**  
*Hand Torque Multiplier with Reaction Plate and Ratcheting Locking System*

- Ratcheting locking system contains the forces generated during tightening which makes possible what otherwise would be difficult, dangerous or even impossible
- Reaction plate with sliding point allows choosing the best reaction point for the job at hand
- Range covers, max output torque up to 9500 Newton Meter
- Use always with torque wrench (CW and CCW) to avoid exceeding the maximum torque of the multiplier
- Accuracy ±4%
- Supplied in portable fabric bag up to 3400 Newton Meter and in rigid case with wheels on sizes above
- Made in UK

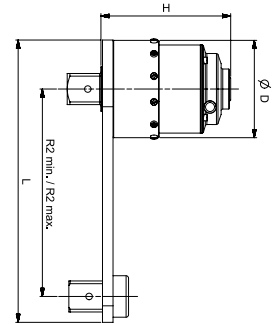

Icon	PAN 731415	Icon	MAX Nm	Icon	Icon	MAX Nm	Icon	D mm	H mm	L mm	R2 min mm	R2 max mm	kg
9525-3400	0125524	1	3400	1	27:1	125	1/2	119	132	355	86	263	10.000
9625-9500	0125555	1	9500	1.1/2	27:1	351	3/4	184	162	448	175	351	25.700





**95155B/9526B**

**Hand Torque Multiplier with Straight Reaction Arm**

- Ratcheting locking system available on all multipliers
- Angle protractor for easy torque and angle tightening
- Range covers max output torque up to 4,500 N-m
- Always use with a torque wrench (CW and ACW) to avoid exceeding the maximum torque of the multiplier
- Accuracy ±4%
- The ratcheting locking system contains the forces generated during tightening which makes it easy to do what would otherwise be difficult, dangerous or even impossible
- Supplied with straight reaction bar
- Supplied in a portable plastic case with foam inlay
- True 15.5:1 (3,000 N-m) or 27:1 (4,500 N-m) torque multiplication ratios allow the use of a small torque wrench
- Made in the UK

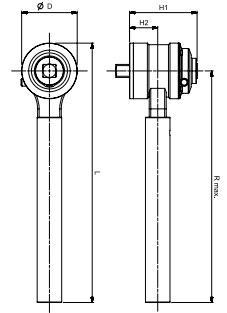

								D mm	H1 mm	H2 mm	L mm	R2 max mm	kg	
95155B-3000	0415410	1	3000	1	15.5:1	193	1/2	108	131	55	504	450	1.9	6.1
9526B-4500	0415427	1	4500	1	27:1	166	1/2	108	149	55	504	450	1.9	7.0



**89222CR/96255CR**

**Compact Hand Torque Multiplier with Offset Reaction Arm**

- Ratcheting locking system available on all multipliers
- Range covers max output torque up to 7,000 N-m
- Always use with torque wrench (CW and ACW) to avoid exceeding the maximum torque of the multiplier
- Accuracy ±4%
- Ratcheting locking system contains the forces generated during tightening which makes it easy to do what would otherwise be difficult, dangerous or even impossible
- Compact dimensions allow excellent access to applications and easy, safe handling
- Lightweight for torque capacity
- Supplied with offset reaction arm
- Supplied in a portable plastic case with foam
- Each multiplier is supplied with its own unique calibration certificate allowing the accurate calculation of input torque for critical applications
- Made in the UK

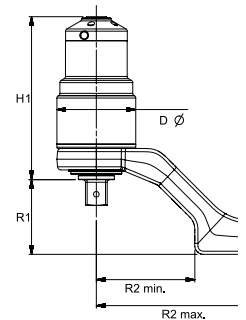

								D mm	H1 mm	R1 mm	R2 min mm	R2 max mm	kg	
89222CR-1000	0415441	1	1000	3/4	22.2:1	45	1/2	52	130	58	71	131	0.9	1.4
9527CR-2000	0415458	1	2000	1	27:1	74	1/2	72	154	72	91	166	1.4	3.2
9525CR-4000	0415465	1	4000	1	25:1	160	1/2	92	190	87	115	205	2.5	5.4
96255CR-7000	0415489	1	7000	1.1/2	25.5:1	274	1/2	119	212	117	151	199	4.0	9.3





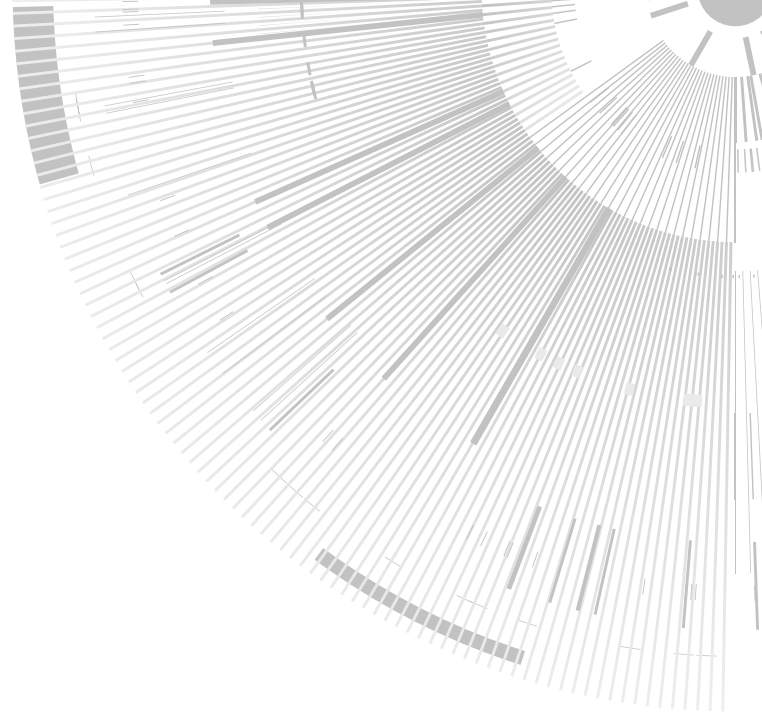

The Multifunctional Testers provide the complete solution for torque tool checking, data logging and data management. They are designed to verify torque screwdrivers as well as small and big torque wrenches. When used with rundowns or joint simulators, pulse tools can be verified to detect whether they deliver constant torque.

# ***TORQUE TESTERS***

- *Multifunctional Testers*
- *Joint Simulators*

# TORQUE TESTERS

## Multifunction Testers

Accuracy +/-1% CW.

Allows up to 10 target torque settings and respective tolerances.

1/2" square drive for TEA350 and 27 mm male hex drive for TEA1100.

Can be connected to an external PC or tablet for data storage.



Peak, first peak and track operational modes.

Easy to use four button interface.

IP40 solid particle protection.



Micro USB socket allows two-way communication to a PC or tablet.

Powered via a micro-USB socket through supplied multi charger or optional USB power packs, PC USB output or vehicles.



USB connection allows torque measurement report creation and storage as well as power feed.



Audible beep warning to stop applying force when target torque is reached.



Visual warnings:  
· Value on screen.  
· Progressive line on screen.

COLOR CODING:  
· torque NOK - low  
· torque OK  
· torque NOK - overtorque



Full range on portable blow mould cases.



Multiple measurement units: N-m, ft.lb, in.lb.



±1% CW optional also ACW with UKAS certificate.



Female 1/2" square chive on 350 N-m size and 27 mm male hex on 1,100 N-m size.



Digital torque reading to know the torque being applied at every moment.



Factory calibration certificate supplied with the product. Optional UKAS certificate in CW and ACW working directions.

**TEA003-TEA030**

**Multifunction Testers for Screwdrivers and Wrenches**



- Ideal tool for checking torque wrenches in workshops, garages and production lines
- Units of measure: Up to 12 selectable units like Nm, lbf.ft, lbf.in
- Easy to use (4 button interface).
- It can be used CW at temperature range -10°C / +50°C
- Allows up to 10 target torque settings and respective tolerances
- Micro-USB socket allows communication to PC or tablet.
- NO internal memory but can be connected to an external PC or tablet for data storage
- Operational modes: Peak (Dial), 1st peak (click) and track
- Accuracy ±1% CW
- Visual (backlit LCD display) signal
- IP40
- Horizontal & vertical mounting options
- Powered via Micro-USB socket Can also be powered from: USB power packs, PC USB output & vehicles via USB. Includes 110/220V universal charger
- Supplied in sturdy plastic case with foam
- Supplied with a factory declaration of conformity traceable to International Standards and CE marking
- Made in UK

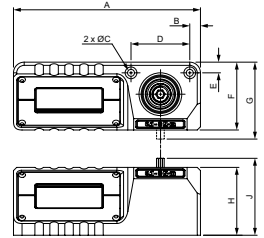

										A	B	C	D	E	F	G	H	J	
	731415									mm	mm	mm	mm	mm	mm	mm	mm	mm	
TEA003	0422180			0.1-3.0	0.89-26.5	0.074-2.212	-	1/4	0,01	175	10	6.5	55	10	64	N/A	64	72	1.4
TEA010	0422197			0.5-10	4.43-88.5	0.37-7.37	-	1/4	0,01	175	10	6.5	55	10	64	N/A	64	72	1.4
TEA030A	0522750			1.5-30	13.3-265	1.11-22.1	-	10	0,1	175	10	6.5	55	10	64	72	64	N/A	1.4



**TJS**

**Joint Simulators for Torque Testing Equipment**

- Joint simulators or rundowns, allow testing pulse tools on torque measuring equipment
- Measuring torque ensures consistent torque fastening operations
- Joint simulators transform pulse tools force into a smooth continuous application of force
- Rundowns never simulate real applications or real joints
- Use rundowns to avoid slamming and ensure repeatable joints
- Rundowns work only clockwise
- If counterclockwise operation is needed, please contact BAHCO.

						L		
		731415			mm	mm		
TJS003		0522477	1	3	1/4	90	31	0.30
TJS010		0522484	1	10	1/4	90	31	0.30
TJS030		0522491	1	30	1/4	90	31	0.30



## TEA065-TEA2100 Multifunction Testers for Torque Wrenches



- Ideal tool for checking torque wrenches in workshops, garages and production lines
- Units of measurement: N-m, lbf.ft, lbf.in
- Torque range: 3 N-m-2100N-m over four models
- Easy to use (four button interface)
- It can be used CW at a temperature range of -10 °C/+50 °C
- Allows up to 10 target torque settings and respective tolerances
- No internal memory but can be connected to an external PC or tablet for data storage
- Micro-USB socket allows two-way communication to PC or tablet.
- Operational modes: Peak, first peak and track
- Accuracy ±1% CW
- Visual (backlit LCD display) and audio signal
- IP40
- Horizontal and vertical mounting options
- Powered via micro-USB socket. Can also be powered from: USB power packs, PC USB output and vehicles via USB. Includes 110/220V universal charger
- Supplied in a sturdy plastic case with foam
- Supplied with a factory declaration of conformity traceable to International Standards and CE marking
- 2014/30/EC, ISO 6789
- Made in the UK

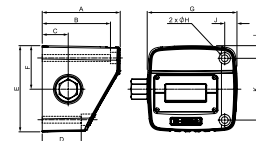

										A	B	C	D	E	F	G		J	K	L	M	
	731415			Nm	in-lb	ft-lb	in	mm	Nm	mm	mm	mm	mm	mm	mm	mm	mm	mm	mm	mm	mm	kg
TEA065	0472246	1	3-65	26.6-575	2.21-47.9	3/8	-	0,1	110	95	40	50	117	59	138	10.5	18.5	19	80	19	-	2.6
TEA350	0422210	1	10-350	89-3098	7.4-258.1	1/2	-	0,1	110	95	40	50	117	59	138	10.5	18.5	19	80	19	-	2.7
TEA1100	0423170	1	50-1100	443-9736	36.9-811.3	3/4	27	1	120	105	40	60	133	67	138	10.5	19	95	20	-	-	3.5
TEA2100	0465972	1	200-2100	1771-18586	148-1548	-	27	1	120	105	40	60	133	67	138	10.5	19	95	20	-	-	3.5



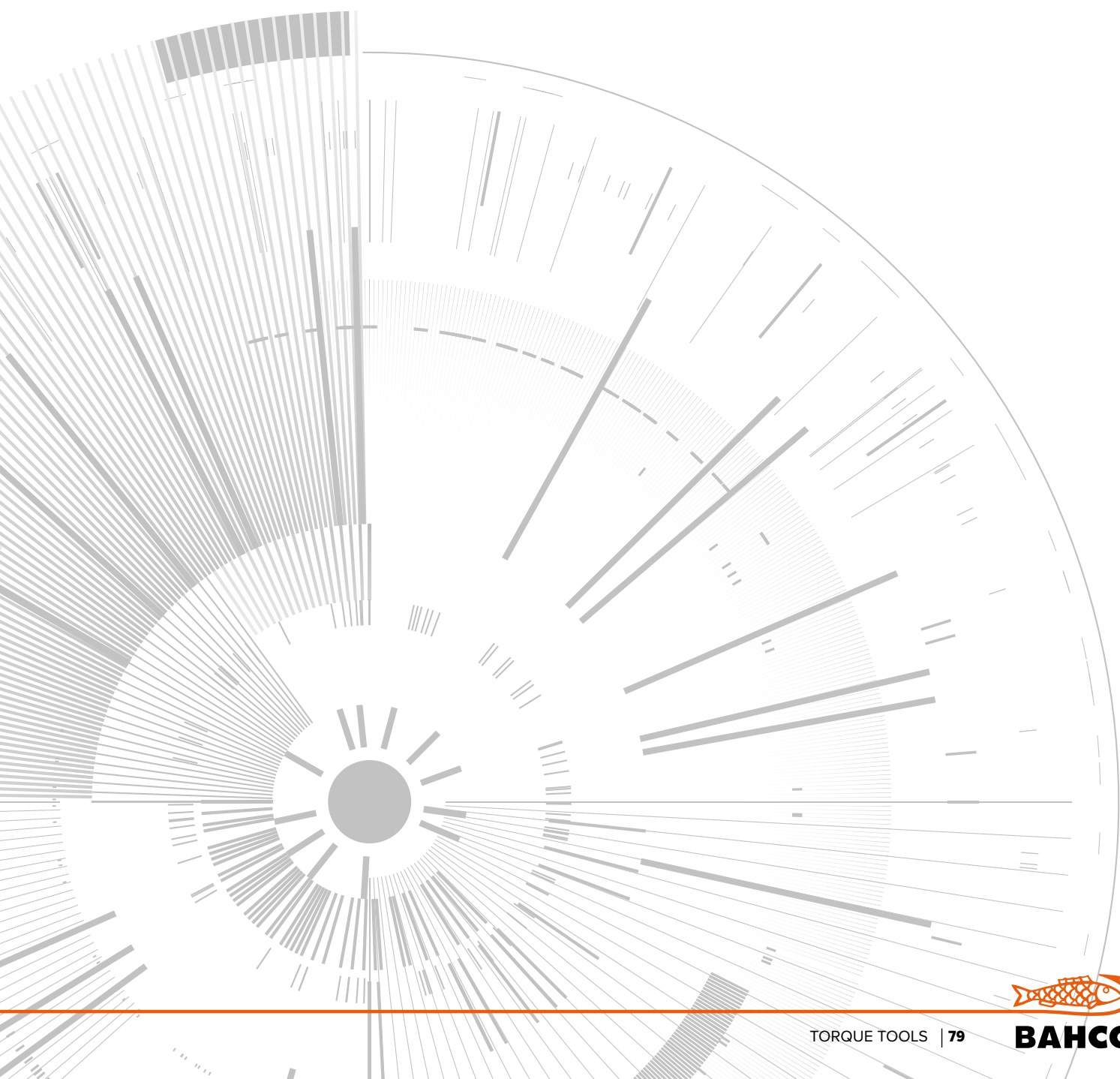





Professional and simple solution for measuring angles while using a torque wrench or transforming a ratchet into a digital torque and angle measurement tool.

For the angle meters, simply place the measuring adaptor onto the Bahco torque wrench via the magnetic base and you can measure the angle quickly and easily without putting the wrench down. They occupy no space in the toolbox, very light and ideal for technicians that are always on the road.

# **TORQUE AND ANGLE ADAPTORS**

- *Digital Torque & Angle Adaptor*
- *Digital Angle Meter*
- *Angle Meter*

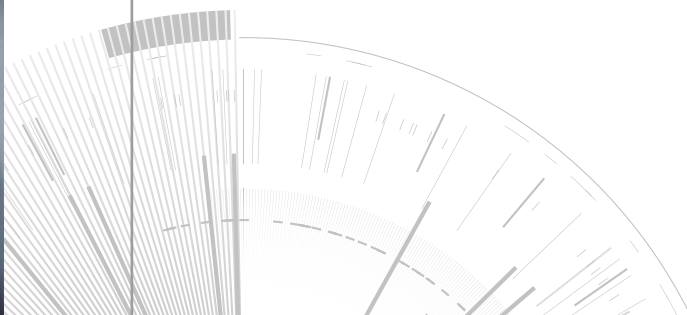

# DIGITAL TORQUE AND ANGLE ADAPTORS

## Electronic Torque and Angle Meter

Accuracy  $\pm 4\%$  in both directions.

Peak and track modes. Multiple units of measurement. Up to 50 stored values and up to 9 presets.

Buzzer makes sounds when approaching and a continuous sound when the target torque is reached.

Works with 2x AA batteries.



Progressive colour LED.

0-360° angle measurement. When a target angle is reached, the final torque and angle values are shown.

Fixed square drives from 1/4" to 1/2" covering torque applications between 1.5 N-m and 340 N-m across the range.

Easy to use and easy to set. Precision and quick settings.

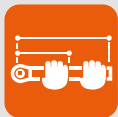

Free-hand point or non-length-dependent feature.



Audible beep warning to stop applying torque.



Visual warnings:  
· Progressive LEDs.  
· LCD screen.



Declaration of conformity comes with the product.



Multiple units of measurement: N-m, ft.lb, in.lb.



Accuracy  $\pm 4\%$  Clockwise. Anticlockwise.



Full range in a hanging colour box, fabric pouch and foam inlay.



Fixed square drive. To use it with any kind of ratchet.



Digital torque reading wrench to know the torque/angle being applied at every moment.



**TAM**  
Digital Torque and Angle Meter



- Transforms any standard ratchet, sliding T handle or break bar into a digital torque and angle measuring tool
- Torque units in N-m, ft.lb, lb.in and angle units in degrees
- Range covers from 1.5 to 340 N-m and from 13 in.lb to 250 ft.lb
- It can be used CW and ACW at temperatures between -10 °C and +60 °C
- Memory for 50 operations and up to 9 presets
- Peak and track modes
- Automatic shut-off
- 2 AAA alkaline batteries included
- More information in user manual
- ±4% CW and ACW
- Visual (dual LEDs + LCD display) and audio signal
- ¼" to ½" fixed square drives
- Supplied in a portable fabric zip case with foam inlay inside a retail cardboard box
- Supplied with a factory declaration of conformity traceable to International Standards and CE marking
- 2004/108/EC, ISO 6789

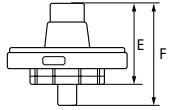
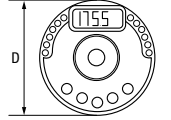

													D mm	E mm	F mm	
				Nm	in-lb	ft-lb	in	in	Nm	in-lb	ft-lb					
TAM1430	0215317	1	1,5-30	13-266	1-22	1/4	1/4	0,01	0,1	0,01	0-360°	90	60	60	0.170	
TAM38135	0215324	1	6,8-135	60-1194	5-100	3/8	3/8	1	1	1	0-360°	80	65	65	0.220	
TAM12135	0215331	1	6,8-135	60-1194	5-100	1/2	1/2	1	1	1	0-360°	80	70	60	0.250	
TAM12200	0215348	1	10-200	88,5-1770	7,4-147,5	1/2	1/2	1	1	1	0-360°	80	70	65	0.250	
TAM12340	0215355	1	17-340	150,5-3009	12,5-251	1/2	1/2	1	1	1	0-360°	85	70	65	0.240	



**MAM**  
Digital Angle Meter



- Allows any torque wrench or standard tool to measure the angle
- Angle units in degrees
- It can be used CW and ACW at temperatures between -10 °C and +60 °C
- Capacity for up to nine presets
- Automatic shut-off
- 2 AAA alkaline batteries included
- More information in user manual
- Accuracy ±2% for a 90° rotation at 30°/s
- Visual (LEDs + LCD display) and audio signal
- Includes a powerful magnet to easily attach the angle meter to any tool
- Supplied in a portable fabric zip case with foam inlay inside a retail cardboard box
- Supplied with a factory declaration of conformity traceable to International Standards and CE marking
- 2004/108/EC, ISO 6789

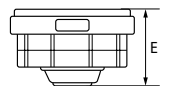
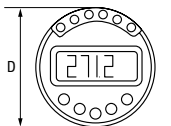

					D mm	E mm	
MAM50M	0215300	1	0-360	56	40	0.060	





### 7851-M/8951-M Angle Meter with Magnet



- Allows any torque wrench or standard tool to measure the angle
- Angle units in degrees
- It can be used CW and ACW
- Continuous visual signal on dial
- Available with 1/2" and 3/4" square drives
- Flexible arm and magnetic fixing

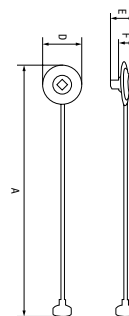

	 731415		 in	A mm	D mm	E mm	F mm	
7851-M	0124893	1	1/2	490	80	40	30	0.370
8951-M	0124916	1	3/4	490	80	40	30	0.550

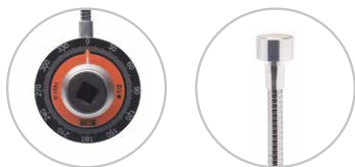

### 7851-G Angle Meter with Clamp



- Allows any torque wrench or standard tool to measure the angle
- Angle units in degrees
- It can be used CW and ACW
- Continuous visual signal on dial
- Available with 1/2" square drive
- Flexible arm and clamp fixing

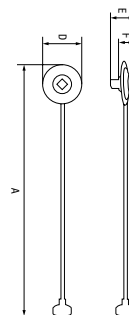

	 731415		 in	A mm	D mm	E mm	F mm	
7851-G	0124909	1	1/2	555	80	40	30	0.350









Insert tools allow you to choose the right head for the job to be done. You can choose between different types of ratchet heads like reversible round head ratchets, pear head ratchets (with and without quick release), push-through ratchets, the most accessible fixed square drive heads; or different wrench end fittings like open end, ring end and flare nut end; or between different kind of adaptors.

There are two types of interchangeable head connections in different sizes to cover application needs up to 2,700 N-m. Most torque wrenches are offered as standard with a quality ratchet.

For applications where interchangeable end fittings are required, 'Torque Handles', which allow for interchangeable spanner fittings, are also available in various models up to 1500 N-m.

# ***INSERT TOOLS***

- *Rectangular Connector Ratchet & Fixed Square Drive*
- *Rectangular Connector Wrenches*
- *Rectangular Connector Adaptor*
- *Round Spigot Connector Ratchet*

# USE OF EXTENSIONS AND ADAPTERS

When using an extension or adapter (increasing the effective length of the torque wrench) the output torque value will change. To calculate the new torque output of the wrench use the following formula:

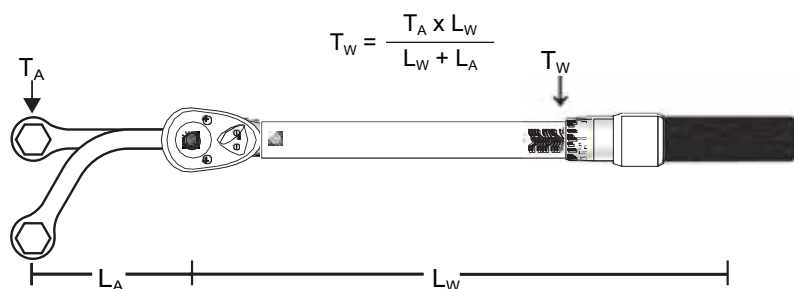

TA = Torque exerted at end of adapter  
 Lw = Distance between square drive and hand position  
 Tw = Wrench scale reading  
 La = Length of adapter or extension

A number of variables including the length of the adapter or extension, length of the wrench and variations in hand position on the wrench will affect the accuracy of the above calculation.

**How do I know if an insert for an interchangeable head torque wrench is exceeding the effective length and I need to use the formula?**

In Bahco catalogue we always indicate C dimension on all the inserts.

If the C dimension value stated on the table exceeds the effective length, it is marked with an asterisk (\*) and the formula needs to be applied.

For any doubt, contact BAHCO.

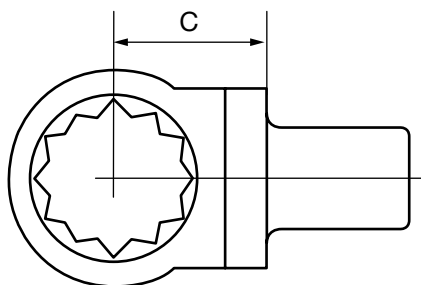

Standard effective length on rectangular inserts by receiver size:

9x12	17.5 mm
14x18	25 mm
24x32	35 mm
27x36	50 mm

## When can I easily find the formula and do the calculation?

You can find an online tightening point displacement calculator in the [BAHCO TORQUE FINDER](#)

## ADVANCED FILTER / ACCESS/WEIGHT NEEDS / TIGHTENING POINT DISPLACEMENT



ADVANCED FILTER  
 ACCESS/WEIGHT NEEDS ^

Max. length (mm)  
 0  
 0 500 1000 1500 2000 1500 3000

Max. width (mm)  
 0  
 0 20 40 60 80 100

Max. weight (kg)  
 0  
 0 6 12 18 24 30

Tightening Point Displacement <

### TIGHTENING POINT DISPLACEMENT

Ta: Target torque to exert (fastener)

Lw: Distance between square drive and hand position

La: Length alteration

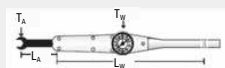

$$T_w = \frac{T_A \times L_w}{L_w + L_A}$$

Tw: Target torque to set at wrench

**9/14/24/27R**

**Round Ratchet Head with Rectangular Connector**



- Round reversible ratchet with 45 teeth
- Insert is fixed to the torque wrench by a spring-loaded retractable pin
- Full range covers from 9x12 to 27x36 receivers, from 1/4 to 1 inch square drives, from 30 N-m max torque to 2,500 N-m
- Suitable for 7465, 74W9, 74W14, 74P9, 74P14, IZO-D, TAW9, TAW14, TAW24, TAWM9, TAWM14, TAWM24 wrenches

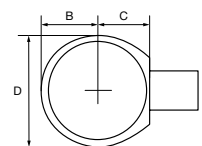
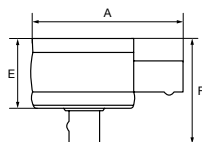

	731415		in	mm	máx	A mm	B mm	C mm	D mm	E mm	F mm	kg
9R-1/4	0365890	1	1/4	9x12	30	49	15	18	30	16	29	0.12
9R-3/8	0365906	1	3/8	9x12	135	53	19	18	38	21	40	0.20
9R-1/2	0365913	1	1/2	9x12	160	54	20	18	40	21	43	0.22
14R-1/2	0365920	1	1/2	14x18	340	70	20	25	40	21	43	0.30
14R-3/4	0365937	1	3/4	14x18	420	70	20	25	40	21	51	0.34
24R-3/4	0365944	1	3/4	24x32	1000	106	30	35	60	32	62	1.03
24R-1	0365951	1	1	24x32	1200	106	30	35	60	32	68	1.12
27R-1	0365968	1	1	27x36	2500	127	36	50	72	42	78	1.91



**9/14/24/27T**

**Push-Through Square Ratchet Head with Rectangular Connector**



- Push-through square drive to allow working CW and ACW without removing the head from the wrench on single direction wrenches
- Ratchet heads with 60 teeth
- Insert is fixed to the torque wrench by a spring-loaded retractable pin
- Full range covers from 9x12 to 27x36 receivers, from 1/4 to 1 inch square drives, from 30 N-m max torque to 2,500 N-m
- Suitable for 7465, 74W9, 74W14, 74P9, 74P14, IZO-D, TAW9, TAW14, TAW24, TAWM9, TAWM14, TAWM24 wrenches
- **Sizes with \* in torque length require target torque setting calculation**

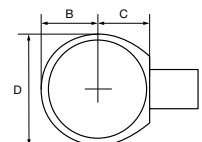
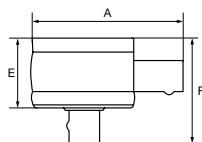

	731415		in	mm	máx	A mm	B mm	C mm	D mm	E mm	F mm	kg
9T-1/4	0366095	1	1/4	9x12	30	61	20	25*	40	17	34	0.220
9T-3/8	0366101	1	3/8	9x12	135	61	20	25*	40	17	36	0.220
9T-1/2	0366118	1	1/2	9x12	160	63	21	25*	42	17	40	0.260
14T-1/2	0366125	1	1/2	14x18	340	72	21	25	42	17	40	0.205
14T-3/4	0366132	1	3/4	14x18	420	99	35	39*	69	26	58	0.940
24T-3/4	0366149	1	3/4	24x32	1000	115	35	39*	69	26	58	1.130
24T-1	0366156	1	1	24x32	1200	138	46	50*	91	32	73	2.180
27T-1	0366163	1	1	27x36	2500	138	46	50	91	32	73	2.255



### 9/14P

#### Pear Ratchet Head with Rectangular Connector



- Pear head reversible ratchet with 22-30 teeth
- Insert is fixed to the torque wrench by a spring-loaded retractable pin
- Range covers from 9x12 to 14x18 receivers, from ¼ to ½ inch square drives, from 30 to 340 N·m
- Suitable for 7465, 74W9, 74W14, 74P9, 74P14, IZO-D, TAW9, TAW14, TAWM9, TAWM14 wrenches
- **Sizes with \* in torque length require target torque setting calculation**

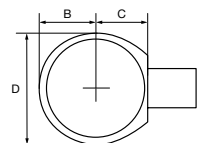
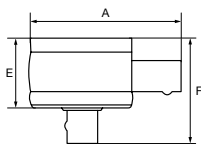

	731415		in	mm	máx	A mm	B mm	C mm	D mm	E mm	F mm	kg
9P-1/4	0366033	1	1/4	9x12	30	75	19	40*	38	19	29	0.240
9P-3/8	0366040	1	3/8	9x12	135	75	19	40*	38	19	32	0.240
9P-1/2	0366057	1	1/2	9x12	160	77	21	40*	42	19	35	0.290
14P-1/4	0366064	1	1/2	14x18	340	86	21	40*	42	19	35	0.380

### 9/14Q

#### Pear Ratchet Head with Quick-Release and Rectangular Connector



- Quick-release pear head reversible ratchet with 22-30 teeth
- Insert is fixed to the torque wrench by a spring-loaded retractable pin
- Range covers from 9x12 to 14x18 receivers, from ¼ to ½ inch square drives, from 30 to 340 N·m
- Suitable for 7465, 74W9, 74W14, 74P9, 74P14, IZO-D, TAW9, TAW14, TAWM9, TAWM14 wrenches
- **Sizes with \* in torque length require target torque setting calculation**

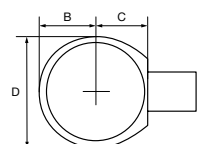
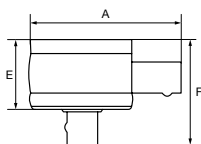

	731415		in	mm	máx	A mm	B mm	C mm	D mm	E mm	F mm	g
9Q-1/4	0365999	1	1/4	9x12	30	75	19	40*	38	19	32	230
9Q-3/8	0366002	1	3/8	9x12	135	75	19	40*	38	19	35	240
9Q-1/2	0366019	1	1/2	9x12	160	77	21	40*	42	19	38	290
14Q-1/2	0366026	1	1/2	14x18	340	86	21	40*	42	19	38	320

**9B**

**Ratchet Head for Screwdriver Bits with Rectangular Connector**



- Pear head reversible bit ratchet with 30 teeth
- Insert is fixed to the torque wrench by a spring-loaded retractable pin
- Range covers in 9x12 receiver 1/4 and 5/16 inch hex drives
- Suitable for 7465, 74W9, 74P9, IZO-D, TAW9, TAWM9
- **Target torque setting must be calculated**

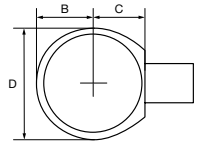
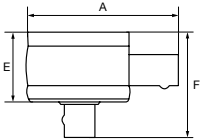

					A	B	C	D	F	
	731415		in	mm	mm	mm	mm	mm	mm	
9B-1/4	0366071	1	1/4	9x12	75	19	40*	38	22	0.240
9B-5/16	0366088	1	5/16	9x12	75	19	40*	38	22	0.250



**9/14/24/27F**

**Fixed Square Head with Rectangular Connector**



- Fixed square drives allow higher accessibility in width and height than ratchet inserts
- Insert is fixed to the torque wrench by a spring-loaded retractable pin
- Full range covers from 9x12 to 27x36 receivers, from 1/4 to 1 inch square drives, from 30 N·m max torque to 2,500 N·m
- Suitable for 7465, 74W9, 74W14, 74P9, 74P14, IZO-D, TAW9, TAW14, TAW24, TAWM9, TAWM14, TAWM24 wrenches
- **Sizes with \* in torque length require target torque setting calculation**

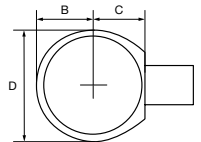
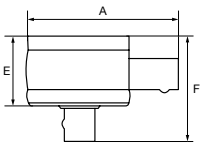

						A	B	C	D	E	F	
	731415		in	mm		mm	mm	mm	mm	mm	mm	
9F-1/4	0366170	1	1/4	9x12	30	43	10	18	22	14	23	0.700
9F-3/8	0366187	1	3/8	9x12	135	44	9	18	22	14	25	0.800
9F-1/2	0366194	1	1/2	9x12	160	45	11	18	22	14	30	0.900
14F-1/2	0366200	1	1/2	14x18	340	65	15	25	30	18	34	0.210
14F-3/4	0366217	1	3/4	14x18	420	69	19	25	40	25	50	0.390
24F-3/4	0366224	1	3/4	24x32	1000	96	20	35	40	28	53	0.730
24F-1	0366231	1	1	24x32	1200	98	22	35	50	28	53	0.750
27F-1	0366248	1	1	27x36	2500	106	25	40*	60	28	57	1.000



### TAH7452-2

#### Reversible Ratchet Head Inserts with Locking Device



- High-performance alloy steel
- Forged chrome finish
- Ratcheting direction is switched with ratchet cover
- Useful with torque wrench TAH7435
- Base ratchet for torque wrench with interchangeable heads adjustment
- Suitable for working at height
- Safety pin locking mechanism ensures positive retention and full functionality
- Colour plate with maximum weight for a right matching with the lanyard
- According to DROPS best practices

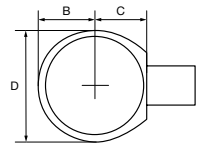
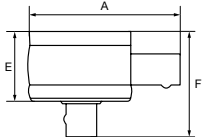

Icon	Part No.	Qty	Unit	Size	Max Torque	A	B	C	D	E	F	Weight
						mm	mm	mm	mm	mm	mm	kg
	731415	1	1/2"	9x12	135	56	20	20*	39	24	39	0.19

### TAH7852-1

#### Reversible Ratchet Insert Tools with Safety Pin Locking Mechanism



- Round type reversible ratchet head insert
- High performance alloy steel
- Ratcheting direction switchable with ratchet cover
- Useful with TAH7435
- Suitable for working at height
- Safety pin locking mechanism ensures positive retention and full functionality
- Colour plate with maximum weight for proper match with lanyard
- Compliant with DROPS best practices

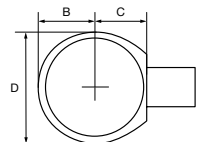
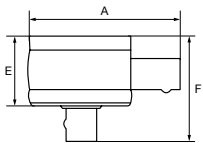

Icon	Part No.	Qty	Unit	Size	Max Torque	A	B	C	D	E	F	Weight
						mm	mm	mm	mm	mm	mm	kg
	731415	1	1/2"	14X18	300	70	20	25	39	24	39	2.65





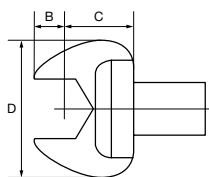
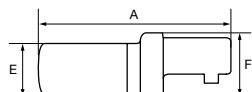

9/14/24/277

Open-End Metric Wrench with Rectangular Connector



- Insert is fixed to the torque wrench by a spring-loaded retractable pin
- Range covers from 9x12 to 27x36 receivers, from 7 to 90 mm openings, from 6 to 3,000 N-m
- **Sizes with \* in torque length require target torque setting calculation**
- Suitable for 7465, 74W9, 74W14, 74P9, 74P14, IZO-D, TAW9, TAW14, TAW24, TAWM9, TAWM14, TAWM24 wrenches



							A	B	C	D	E	F	
	731415			mm	mm	mm	mm	mm	mm	mm	mm	mm	g
97-7	0366255	1	7	9x12	9	40	7,5	17,5	22	5,5	17	30	
97-8	0366262	1	8	9x12	13	40	7,5	17,5	22	5,5	17	40	
97-9	0366279	1	9	9x12	18	40	7,5	17,5	25	6	17	50	
97-10	0366286	1	10	9x12	24	40	7,5	17,5	25	6	17	40	
97-11	0366293	1	11	9x12	32	40	7,5	17,5	25	6	17	30	
97-12	0366309	1	12	9x12	41	40	7,5	17,5	29	7	17	40	
97-13	0366316	1	13	9x12	51	40	7,5	17,5	29	7	17	40	
97-14	0366323	1	14	9x12	63	40	7,5	17,5	33	8	17	60	
97-15	0366330	1	15	9x12	77	42	9,5	17,5	33	8	17	50	
97-16	0366347	1	16	9x12	92	42	9,5	17,5	38	8	17	50	
97-17	0366354	1	17	9x12	109	42	9,5	17,5	38	8	17	60	
97-18	0366361	1	18	9x12	125	50	10	25*	42,5	8	17	130	
97-19	0366378	1	19	9x12	145	50	10	25*	42,5	8	17	80	
97-21	0366385	1	21	9x12	160	55	15	25*	48	8	17	90	
97-22	0349722	1	22	9x12	160	55	15	25*	48	8	17	100	
97-24	0357048	1	24	9x12	160	55	15	25*	52	8	17	100	
97-27	0366392	1	27	9x12	160	58	13	30*	57	8	17	130	
97-30	0366408	1	30	9x12	160	65	15	35*	66	8	17	145	
97-32	0366415	1	32	9x12	160	65	15	35*	66	8	17	180	
147-13	0366644	1	13	14x18	51	55	7	25	32	8	20	120	
147-14	0366651	1	14	14x18	63	55	7	25	32	8	20	116	
147-15	0366668	1	15	14x18	77	57	9	25	32	8	20	120	
147-16	0366675	1	16	14x18	92	55	7	25	38	9	20	128	
147-17	0366682	1	17	14x18	109	57	9	25	38	9	20	140	
147-18	0366699	1	18	14x18	125	60	12	25	42	10	20	140	
147-19	0366705	1	19	14x18	145	60	12	25	42	10	20	150	
147-21	0366712	1	21	14x18	190	62	14	25	48	12	20	158	
147-22	0366729	1	22	14x18	220	63	15	25	48	12	20	180	
147-24	0366736	1	24	14x18	280	63	15	25	52	13	20	190	
147-25	0366743	1	25	14x18	320	60	12	25	52	13	20	180	
147-27	0366750	1	27	14x18	360	67	14	30*	57	14	20	230	
147-30	0366767	1	30	14x18	360	75	17	35*	65	14	20	270	
147-32	0366774	1	32	14x18	360	75	17	35*	65	14	20	260	
147-33	0366781	1	33	14x18	360	83	20	40*	68	14	20	320	
147-34	0366798	1	34	14x18	360	80	17	40*	68	14	20	310	
147-35	0366804	1	35	14x18	360	80	17	40*	68	14	20	310	
147-36	0366811	1	36	14x18	360	80	17	40*	68	14	20	365	
147-37	0366828	1	37	14x18	360	80	7	50*	84	14	20	290	
147-38	0366835	1	38	14x18	360	82	9	50*	84	14	20	300	
147-39	0366842	1	39	14x18	360	90	17	50*	84	14	20	460	
147-41	0366859	1	41	14x18	360	90	17	50*	84	14	20	430	
147-45	0366866	1	45	14x18	360	92	19	50*	90	14	20	490	
147-46	0366873	1	46	14x18	360	90	17	50*	90	14	20	480	
147-50	0366880	1	50	14x18	360	100	22	55*	100	14	20	570	
147-55	0366897	1	55	14x18	360	100	22	55*	100	14	20	530	
147-60	0366903	1	60	14x18	360	110	27	60*	110	14	20	650	
147-65	0537860	1	65	14x18	360	123	30	65*	129	14	20	680	
147-68	0366910	1	68	14x18	360	123	30	70*	129	14	20	890	
147-70	0366927	1	70	14x18	360	123	30	70*	129	14	20	700	
147-75	0366934	1	75	14x18	360	123	30	70*	129	14	20	840	
147-90	0366941	1	90	14x18	360	140	37	80*	156	14	20	1090	
247-24	0367078	1	24	24x32	1200	85	10	35	61	25	35	700	
247-27	0367085	1	27	24x32	1200	85	10	35	66,5	25	35	710	
247-30	0367092	1	30	24x32	1200	90	15	35	68,5	25	35	730	
247-32	0367108	1	32	24x32	1200	90	15	35	68,5	25	35	700	
247-34	0367115	1	34	24x32	1200	90	10	40*	73,5	25	35	730	
247-36	0367122	1	36	24x32	1200	92	12	40*	73,5	25	35	800	
247-41	0367139	1	41	24x32	1200	105	15	50*	86	25	35	1000	
247-46	0367146	1	46	24x32	1200	110	20	50*	92	25	35	1040	
247-50	0367153	1	50	24x32	1200	117	22	55*	104	25	35	1270	
247-55	0367160	1	55	24x32	1200	118	23	55*	104	25	35	1210	
247-60	0367177	1	60	24x32	1200	125	25	60*	114	25	35	1360	
277-30	0367184	1	30	27x36	3000	110	20	50	85	28	40	1295	
277-32	0367191	1	32	27x36	3000	110	20	50	85	28	40	1210	
277-34	0367207	1	34	27x36	3000	105	15	50	88	28	40	1220	
277-36	0367214	1	36	27x36	3000	105	15	50	88	28	40	1200	
277-41	0367221	1	41	27x36	3000	107	17	50	92	28	40	1220	
277-46	0367238	1	46	27x36	3000	110	20	50	98	28	40	1240	
277-50	0367245	1	50	27x36	3000	117	22	55*	118	28	40	1580	
277-55	0367252	1	55	27x36	3000	117	22	55*	118	28	40	1530	
277-60	0367269	1	60	27x36	3000	125	25	60*	130	28	40	1780	









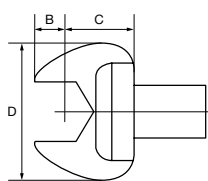
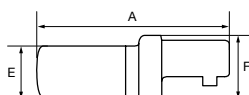

**9/14/24/277"**

**Open-End Imperial Wrench with Rectangular Connector**



- Insert is fixed to the torque wrench by a spring-loaded retractable pin
- Full range covers from 9x12 to 27x36 receivers, from 1/4 to 1 1/4 inch openings, from 6 to 360 N-m
- **Sizes with \* in torque length require target torque setting calculation**
- Suitable for 7465, 74W9, 74W14, 74P9, 74P14, IZO-D, TAW9, TAW14, TAWM9, TAWM14 wrenches



							A	B	C	D	E	F	
		731415		in	mm		mm	mm	mm	mm	mm	mm	g
97-1/4	0366507	1	1/4	9x12	6	40	7,5	17,5	22	5	17	38	
97-5/16	0366514	1	5/16	9x12	13	40	7,5	17,5	22	5	17	37	
97-3/8	0366521	1	3/8	9x12	24	40	7,5	17,5	26	5,5	17	43	
97-7/16	0366538	1	7/16	9x12	32	40	7,5	17,5	26	5,5	17	42	
97-1/2	0366545	1	1/2	9x12	51	40	7,5	17,5	30	7	17	47	
97-17/32	0366552	1	17/32	9x12	63	41	8,5	17,5	35	8	17	58	
97-9/16	0366569	1	9/16	9x12	77	40	7,5	17,5	35	8	17	57	
97-5/8	0366576	1	5/8	9x12	92	43	10,5	17,5	38	8	17	56	
97-11/16	0366583	1	11/16	9x12	125	55	15	25*	42	8	17	80	
97-3/4	0366590	1	3/4	9x12	145	50	10	25*	42	8	17	75	
97-13/16	0366606	1	13/16	9x12	160	50	9	25*	50	8	17	100	
97-7/8	0366613	1	7/8	9x12	160	52	10	25*	50	8	17	95	
97-15/16	0366620	1	15/16	9x12	160	45	5	25	53	8	17	110	
97-1	0366637	1	1	9x12	160	60	20	25*	53	8	17	110	
147-7/16	0366958	1	7/16	14x18	32	55	7	25	30	7	20	114	
147-1/2	0366965	1	1/2	14x18	51	55	7	25	32	7	20	110	
147-9/16	0366972	1	9/16	14x18	77	55	7	25	35	8	20	115	
147-5/8	0366989	1	5/8	14x18	92	55	7	25	38	9	20	128	
147-11/16	0366996	1	11/16	14x18	109	53	5	25	38	9	20	127	
147-3/4	0367009	1	3/4	14x18	145	60	12	25	42	10	20	137	
147-13/16	0367016	1	13/16	14x18	190	62	14	25	50	11	20	158	
147-7/8	0367023	1	7/8	14x18	220	60	12	25	50	11	20	155	
147-15/16	0367030	1	15/16	14x18	280	63	15	25	53	13	20	159	
147-1	0367047	1	1	14x18	360	60	12	25	53	13	20	163	
147-1 1/8	0367054	1	1 1/8	14x18	360	68	15	30*	68	13	20	255	
147-1 1/4	0367061	1	1 1/4	14x18	360	75	17	35*	70	13	20	255	





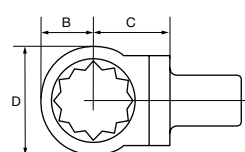
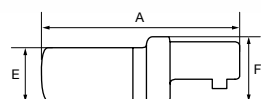

9/14/24/278

Ring End Metric Wrench with Rectangular Connector



- Insert is fixed to the torque wrench by a spring-loaded retractable pin
- Full range covers from 9x12 to 27x36 receivers, from 7 to 60 mm openings, from 25 to 3,000 N-m
- **Sizes with \* in torque length require target torque setting calculation**
- Suitable for 7465, 74W9, 74W14, 74P9, 74P14, IZO-D, TAW9, TAW14, TAW24, TAWM9, TAWM14, TAWM24 wrenches



		 731415		 mm	 mm	 mm	A mm	B mm	C mm	D mm	E mm	F mm	 g
98-7	0367290	1	7	9x12	25	40	7,5	17,5	22	8	20	43	
98-8	0367306	1	8	9x12	34	40	7,5	17,5	22	8	20	40	
98-9	0367313	1	9	9x12	45	40	7,5	17,5	22	9	20	50	
98-10	0367320	1	10	9x12	58	42	9,5	17,5	22	9	20	48	
98-11	0367337	1	11	9x12	47	42	9,5	17,5	22	9	20	40	
98-12	0367344	1	12	9x12	89	42	9,5	17,5	22	12	20	50	
98-13	0367351	1	13	9x12	105	42	9,5	17,5	22	12	20	60	
98-14	0367368	1	14	9x12	125	45	12,5	17,5	23	12	20	60	
98-15	0367375	1	15	9x12	145	45	12,5	17,5	25	12	20	60	
98-16	0367382	1	16	9x12	160	45	12,5	17,5	27,5	13	20	60	
98-17	0367399	1	17	9x12	160	45	12,5	17,5	27,5	13	20	55	
98-18	0367405	1	18	9x12	160	42	9,5	17,5	29	13	20	58	
98-19	0367412	1	19	9x12	160	55	22,5	17,5	31	13	20	90	
98-21	0367429	1	21	9x12	160	49	16,5	17,5	33,5	13	20	68	
98-22	0367436	1	22	9x12	160	50	17,5	17,5	35	13	20	70	
148-13	0367559	1	13	14x18	105	60	12	25	32	11	25	140	
148-14	0367566	1	14	14x18	125	60	12	25	32	11	25	140	
148-15	0367573	1	15	14x18	150	60	12	25	32	11	25	140	
148-16	0367580	1	16	14x18	175	60	12	25	32	12	25	140	
148-17	0367597	1	17	14x18	200	62	14	25	32	12	25	150	
148-18	0367603	1	18	14x18	230	63	15	25	32	12	25	150	
148-19	0367610	1	19	14x18	260	64	16	25	32	12	25	138	
148-21	0367627	1	21	14x18	330	64	16	25	33	15	25	170	
148-22	0367634	1	22	14x18	360	55	7	25	35	15	25	170	
148-24	0367641	1	24	14x18	360	62	14	25	38	15	25	170	
148-27	0367658	1	27	14x18	360	75	22	30	41,5	17,5	25	210	
148-28	0367665	1	28	14x18	360	75	22	30	44	17,5	25	210	
148-30	0367672	1	30	14x18	360	78	25	30	45	17,5	25	210	
148-32	0367689	1	32	14x18	360	78	25	30	47,5	17,5	25	210	
148-34	0367696	1	34	14x18	360	80	27	30*	51	19	25	190	
148-36	0367702	1	36	14x18	360	80	27	30*	53	19	25	196	
148-41	0367719	1	41	14x18	360	88	30	35*	59,5	19	25	280	
248-24	0367818	1	24	24x32	1200	100	25	35	48	25	35	880	
248-27	0367825	1	27	24x32	1200	105	30	35	50	25	35	910	
248-30	0367832	1	30	24x32	1200	105	30	35	55	25	35	720	
248-32	0367849	1	32	24x32	1200	103	28	35	57	25	35	730	
248-34	0367856	1	34	24x32	1200	105	30	35	61	25	35	740	
248-36	0367863	1	36	24x32	1200	110	30	40*	62	25	35	790	
248-41	0367870	1	41	24x32	1200	120	35	45*	73	25	35	960	
248-46	0367887	1	46	24x32	1200	125	40	45*	82	25	35	1040	
248-50	0367894	1	50	24x32	1200	137	47	50*	95	25	35	1300	
248-55	0367900	1	55	24x32	1200	145	50	55*	102	25	35	1450	
248-60	0367917	1	60	24x32	1200	153	53	60*	110	25	35	1620	
278-30	0367924	1	30	27x36	3000	125	35	50	70	28	40	1270	
278-32	0367931	1	32	27x36	1240	125	35	50	70	28	40	1213	
278-34	0367948	1	34	27x36	3000	125	35	50	78	25	40	1250	
278-36	0367955	1	36	27x36	3000	125	35	50	75	28	40	1220	
278-41	0367962	1	41	27x36	3000	128	38	50	76	28	40	1220	
278-46	0367979	1	46	27x36	3000	137	47	50	82	28	40	1260	
278-50	0367986	1	50	27x36	3000	135	45	50	92	28	40	1430	
278-55	0367993	1	55	27x36	3000	135	40	55*	104	28	40	1700	
278-60	0368006	1	60	27x36	3000	148	48	60*	110	28	35	1570	







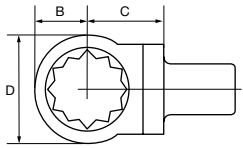
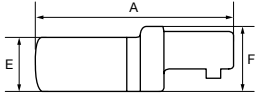

**9/14/24/278"**

**Ring End Imperial Wrench with Rectangular Connector**



- Insert is fixed to the torque wrench by a spring-loaded retractable pin
- Range covers 9x12 and 14x18 receivers, from 1/4 to 1 inch openings, from 25 to 360 N-m
- Suitable for 7465, 74W9, 74W14, 74P9, 74P14, IZO-D, TAW9, TAW14, TAWM9, TAWM14 wrenches



						A	B	C	D	E	F	
	731415		in	mm	max	mm	mm	mm	mm	mm	mm	kg
98-1/4	0367443	1	1/4	9x12	25	40	7,5	17,5	13	8	20	0,043
98-5/16	0367450	1	5/16	9x12	34	40	7,5	17,5	14	8	20	0,042
98-3/8	0367467	1	3/8	9x12	58	42	9,5	17,5	17	9	20	0,048
98-7/16	0367474	1	7/16	9x12	72	42	9,5	17,5	18,5	9	20	0,05
98-1/2	0367481	1	1/2	9x12	105	43	10,5	17,5	22	12	20	0,053
98-9/16	0367498	1	9/16	9x12	125	45	12,5	17,5	23	12	20	0,052
98-5/8	0367504	1	5/8	9x12	160	46	13,5	17,5	26	13	20	0,06
98-11/16	0367511	1	11/16	9x12	160	45	12,5	17,5	28,5	13	20	0,058
98-3/4	0367528	1	3/4	9x12	57	48	15,5	17,5	30	13	20	0,06
98-13/16	0367535	1	13/16	9x12	160	49	16,5	17,5	33	13	20	0,068
98-7/8	0367542	1	7/8	9x12	160	50	17,5	17,5	34,5	13	20	0,06
148-1/2	0367726	1	1/2	14x18	105	60	12	25	21,5	11	25	0,14
148-9/16	0367733	1	9/16	14x18	150	60	12	25	24	11	25	0,15
148-5/8	0367740	1	5/8	14x18	175	60	12	25	26	12	25	0,14
148-11/16	0367757	1	11/16	14x18	230	62	14	25	28,5	12	25	0,15
148-3/4	0367764	1	3/4	14x18	260	65	17	25	30,5	12	25	0,138
148-13/16	0367771	1	13/16	14x18	330	65	17	25	33	15	25	0,17
148-15/16	0367795	1	15/16	14x18	360	65	17	25	37,5	15	25	0,16
148-7/8	0367788	1	7/8	14x18	360	66	18	25	34,5	15	25	0,17
148-1	0367801	1	1	14x18	360	68	20	25	40	15	25	0,16





**9/14/24W**

**Welding insert with Rectangular Connector**

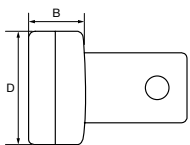
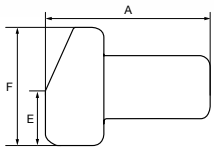

- Special insert to weld any other size, opening or wrench type not included in the Bahco insert assortment
- Insert is fixed to the torque wrench by a spring-loaded retractable pin
- Full range covers from 9x12 to 24x32 receivers
- Suitable for 7465, 74W9, 74W14, 74P9, 74P14, IZO-D, TAW9, TAW14, TAW24, TAWM9, TAWM14, TAWM24 wrenches
- **Target torque setting must be calculated**



				A	B	D	E	F	
	731415		mm	mm	mm	mm	mm	mm	kg
9W	0354399	1	9x12	23	9	21,5	8	21	0.027
14W	0357031	1	14x18	37	17.5	20	8	29	0.090
24W	0368266	1	24x32	65	20	25	9	32	0.160

99

Flare Nut End Wrench with Rectangular Connector



- Insert is fixed to the torque wrench by a spring-loaded retractable pin
- Full range covers in 9x12 receiver from 10 to 24 mm openings, from 3/4 to 3/4 inch openings, from 9 to 96 N-m
- **Sizes with \* in torque length require target torque setting calculation**
- Suitable for 7465, 74W9, 74P9, 74P14, IZO-D, TAW9, TAWM9 wrenches

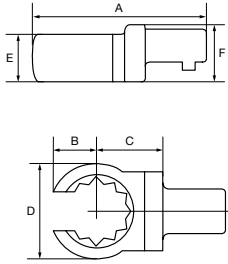

							A mm	B mm	C mm	D mm	E mm	F mm	
99-10	0368013	1	10	9x12	14	43	2,5	17,5	22	12	17	63	
99-11	0368020	1	11	9x12	19	42	1,5	17,5	22	12	17	62	
99-12	0368037	1	12	9x12	24	63	2,5	17,5	24	12	17	61	
99-13	0368044	1	13	9x12	30	43	10,5	17,5	25	12	17	63	
99-14	0368051	1	14	9x12	37	45	4,5	17,5	27	12	17	62	
99-16	0368068	1	16	9x12	46	46	5,5	17,5	28	13	14	69	
99-17	0368075	1	17	9x12	55	45	4,5	17,5	30	13	17	69	
99-18	0368082	1	18	9x12	65	55	14,5	17,5	31,5	13	17	68	
99-19	0368099	1	19	9x12	74	55	15	25*	33	13	17	77	
99-21	0368105	1	21	9x12	87	55	15	25*	35	13	17	92	
99-22	0368112	1	22	9x12	96	55	15	25*	37	13	17	95	
99-24	0368129	1	24	9x12	96	56	16	25*	40	13	17	97	
99-3/8	0368136	1	3/8	9x12	9	40	0,5	17,5	22	12	17	63	
99-7/16	0368143	1	7/16	9x12	16	40	0,5	17,5	22	12	17	62	
99-1/2	0368150	1	1/2	9x12	28	43	2,5	17,5	25	12	17	63	
99-9/16	0368167	1	9/16	9x12	31	45	4,5	17,5	27	13	17	62	
99-5/8	0368174	1	5/8	9x12	46	43	2,5	17,5	30	13	17	69	
99-11/16	0368181	1	11/16	9x12	65	52	4	25	33	13	17	77	
99-3/4	0368198	1	3/4	9x12	74	55	7	25	34,5	13	17	82	

9/14/24/27A

Increasing and Reducing Rectangular Connector Adaptors



- It allows adapting your wrench to inserts with a smaller or bigger receiver
- Insert is fixed to the torque wrench by a spring-loaded retractable pin
- Full range covers from 9x12 to 24x32 receivers
- Suitable for 7465, 74W9, 74W14, 74P9, 74P14, IZO-D, TAW9, TAW14, TAW24, TAWM9, TAWM14, TAWM24 wrenches
- **Torque length is altered and the target torque setting must be calculated**

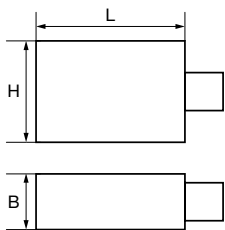

						L mm	B mm	H mm	
9A-14	0368204	1	9x12	14x18	42	30	24	0.180	
14A-9	0368211	1	14x18	9x12	27	21	17	0.100	
14A-932	0368228	1	14x18	24x32	65	56	38	1.180	
24A-14	0368235	1	24x32	14x18	42	32	25	0.420	
24A-27	0368242	1	24x32	27x36	65	64	42	1.040	
27A-24	0368259	1	27x36	24x32	65	56	38	0.980	





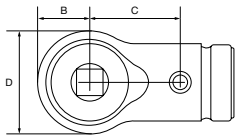
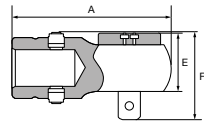

**16R/22R**

*Round Ratchet Head with Spigot Connector*



- Round reversible ratchet with 45 teeth
- Insert is fixed to the torque wrench by a spring-loaded retractable pin
- Full range covers from 16 to 22 mm receivers, from 1/4 to 3/4 inch square drives and from 20 N-m to 1,200 N-m max torque
- Suitable for 74WS and 75S wrenches



	 731415		 in	 mm	 max	A mm	B mm	C mm	D mm	E mm	F mm	 kg
16R-1/4	0418589	1	1/4"	16	20	110	30	56	60	32	60	1.200
16R-3/8	0418596	1	3/8"	16	160	70	19	32	38	21	39	0.175
16R-1/2	0418602	1	1/2"	16	420	71	20	32	40	21	42	0.280
22R-3/4	0419838	1	3/4"	22	1200	70	19	32	38	21	35	0.150



# **BITS, SOCKETS AND ACCESSORIES**



Impact Sockets and Ratchets



Non Sparking Sockets and Ratchets



Sockets and Ratchets



Screwdriver Bits



TatH Sockets and Ratchets

# ADJUSTABLE CROWFOOT



## Effective length for torque applications

Crowfoot wrenches are often used in torque applications for reaching hidden bolts or for bolts you can not fasten with a socket. The use of crowfoot wrenches in torque applications implies the calculation of the torque to be set on the torque tool in order to reach the target torque at the fastener.

### FORMULA

$$T_w = T_L \frac{c}{c+L} \quad \text{where}$$

$T_w$  is the torque to be set on the torque wrench

$T_L$  is the target torque at the fastener

$C$  is the effective length of the torque wrench (distance from square drive to hand position)

$L$  is the effective length of the crowfoot wrench (distance from square drive center to bolt center)

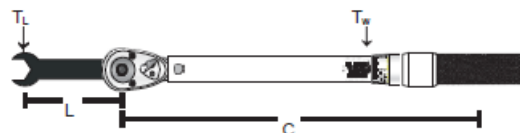

### EFFECTIVE LENGTH ON A CROWFOOT WRENCH

On the website and catalogues we show the effective length of the crowfoot wrenches with dimension L (see figure)

We give this distance on all crowfoot wrenches except on the adjustable crowfoot wrench, reference 1950MZ 3/8

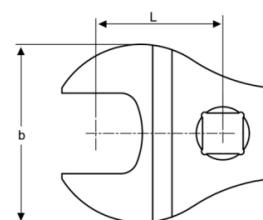

### CALCULATION OF THE EFFECTIVE LENGTH ON ADJUSTABLE CROWFOOT WRENCH

A formula needs to be applied for hex head bolts with across flats dimension (s) below 24 mm and a different one for s sizes above 24 mm



#### FORMULA FOR $S \leq 24$ MM

$$L = 34 + \frac{s}{2 \times \sqrt{3}}$$

#### FORMULA FOR $S > 24$ MM

$$L = 28 + \frac{s}{\sqrt{3}}$$

S mm	L mm
6	35.7
7	36.0
8	36.3
9	36.6
10	36.9
11	37.2
12	37.5
13	37.8
14	38.0
15	38.3
16	38.6
17	38.9

S mm	L mm
18	39.2
19	39.5
20	39.8
21	40.1
22	40.4
23	40.6
24	40.9
25	42.4
26	43.0
27	43.6
28	44.2
29	44.7

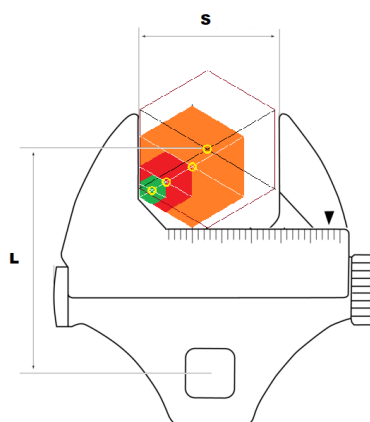

# UNIT CONVERSION TABLE

## lbf-ft to N·m

ft.lb	0 ft.lb	1 ft.lb	2 ft.lb	3 ft.lb	4 ft.lb	5 ft.lb	6 ft.lb	7 ft.lb	8 ft.lb	9 ft.lb
0	0.00	1.36	2.71	4.07	5.42	6.78	8.13	9.49	10.85	12.20
10	13.56	14.91	16.27	17.63	18.98	20.34	21.69	23.05	24.40	25.76
20	27.12	28.47	29.83	31.18	32.54	33.90	35.25	36.61	37.96	39.32
30	40.67	42.03	43.39	44.74	46.10	47.45	48.81	50.17	51.52	52.88
40	54.23	55.59	56.94	58.30	59.66	61.01	62.37	63.72	65.08	66.44
50	67.79	69.15	70.50	71.86	73.21	74.57	75.93	77.28	78.64	79.99
60	81.35	82.71	84.06	85.42	86.77	88.13	89.48	90.84	92.20	93.55
70	94.91	96.26	97.62	98.97	100.33	101.69	103.04	104.40	105.75	107.11
80	108.47	109.82	111.18	112.53	113.89	115.24	116.60	117.96	119.31	120.67
90	122.02	123.38	124.74	126.09	127.45	128.80	130.16	131.51	132.87	134.23
100	135.58								1 ft.lb = 1.35582 N·m	

## cN·m to ozf-in

cN·m	0 cN·m	1 cN·m	2 cN·m	3 cN·m	4 cN·m	5 cN·m	6 cN·m	7 cN·m	8 cN·m	9 cN·m
0	0.00	1.42	2.83	4.25	5.66	7.08	8.50	9.91	11.33	12.75
10	14.16	15.58	16.99	18.41	19.83	21.24	22.66	24.07	25.49	26.91
20	28.32	29.74	31.15	32.57	33.99	35.40	36.82	38.24	39.65	41.07
30	42.48	43.90	45.32	46.73	48.15	49.56	50.98	52.40	53.81	55.23
40	56.64	58.06	59.48	60.89	62.31	63.73	65.14	66.56	67.97	69.39
50	70.81	72.22	73.64	75.05	76.47	77.89	79.30	80.72	82.13	83.55
60	84.97	86.38	87.80	89.22	90.63	92.05	93.46	94.88	96.30	97.71
70	99.13	100.54	101.96	103.38	104.79	106.21	107.63	109.04	110.46	111.87
80	113.29	114.71	116.12	117.54	118.95	120.37	121.79	123.20	124.62	126.03
90	127.45	128.87	130.28	131.70	133.12	134.53	135.95	137.36	138.78	140.20
100	141.61								1 cN·m = 1.41612 ozf.in	

## N·m to lbf-ft

N·m	0 N·m	1 N·m	2 N·m	3 N·m	4 N·m	5 N·m	6 N·m	7 N·m	8 N·m	9 N·m
0	0	0.74	1.48	2.21	2.95	3.69	4.43	5.16	5.90	6.64
10	7.38	8.11	8.85	9.59	10.33	11.06	11.80	12.54	13.28	14.01
20	14.75	15.49	16.23	16.96	17.70	18.44	19.18	19.91	20.65	21.39
30	22.13	22.86	23.60	24.34	25.08	25.81	26.55	27.29	28.03	28.76
40	29.50	30.24	30.98	31.72	32.45	33.19	33.93	34.67	35.40	36.14
50	36.88	37.62	38.35	39.09	39.83	40.57	41.30	42.04	42.78	43.52
60	44.25	44.99	45.73	46.47	47.20	47.94	48.68	49.42	50.15	50.89
70	51.63	52.37	53.10	53.84	54.58	55.32	56.05	56.79	57.53	58.27
80	59.00	59.74	60.48	61.22	61.96	62.69	63.43	64.17	64.91	65.64
90	66.38	67.12	67.86	68.59	69.33	70.07	70.81	71.54	72.28	73.02
100	73.76								1 N·m = 0.73756 ft lb	

## ozf-in to N·m

in.oz	0 in.oz	1 in.oz	2 in.oz	3 in.oz	4 in.oz	5 in.oz	6 in.oz	7 in.oz	8 in.oz	9 in.oz
0	0	0.007	0.014	0.021	0.028	0.035	0.042	0.049	0.056	0.064
10	0.071	0.078	0.085	0.092	0.098	0.106	0.113	0.120	0.127	0.134
20	0.141	0.148	0.155	0.162	0.169	0.177	0.184	0.191	0.198	0.205
30	0.212	0.219	0.226	0.232	0.240	0.247	0.254	0.261	0.268	0.275
40	0.282	0.289	0.297	0.304	0.312	0.318	0.325	0.332	0.339	0.346
50	0.353	0.360	0.367	0.374	0.381	0.388	0.395	0.402	0.409	0.417
60	0.424	0.431	0.438	0.445	0.452	0.459	0.466	0.473	0.480	0.487
70	0.494	0.501	0.508	0.515	0.522	0.530	0.537	0.544	0.551	0.558
80	0.565	0.572	0.579	0.586	0.593	0.600	0.607	0.614	0.621	0.628
90	0.635	0.642	0.650	0.657	0.664	0.671	0.678	0.685	0.692	0.699
100	0.706								in oz x 0.00706 = N·m	

## kg·m to lbf-ft

kg·m	0 kg·m	1 kg·m	2 kg·m	3 kg·m	4 kg·m	5 kg·m	6 kg·m	7 kg·m	8 kg·m	9 kg·m
0	0	7.23	14.47	21.70	28.93	36.17	43.40	50.63	57.86	65.10
10	72.4	79.6	86.8	94.0	101.3	108.5	115.7	123.0	130.2	137.4
20	144.7	151.9	159.1	166.4	173.6	180.8	188.1	195.3	202.5	209.8
30	217.0	224.2	231.5	238.7	245.9	253.2	260.4	267.6	274.9	282.1
40	289.3	296.6	303.9	311.0	318.3	325.5	332.7	340.0	347.2	354.4
50	361.7	368.9	376.1	383.3	390.6	397.8	405.0	412.3	419.5	426.7
60	434.0	441.2	448.4	455.7	462.9	470.1	477.4	484.6	491.8	499.1
70	506.3	513.5	520.8	528.0	535.2	542.5	549.7	556.9	564.2	571.4
80	578.6	585.9	593.1	600.3	607.6	614.8	622.0	629.3	636.5	643.7
90	651.0	658.2	665.4	672.7	679.9	687.1	694.4	701.6	708.8	716.1
100	723.3								kg m x 7.233 = lb ft	

## lbf-ft to kg·m

ft.lb	0 ft.lb	1 ft.lb	2 ft.lb	3 ft.lb	4 ft.lb	5 ft.lb	6 ft.lb	7 ft.lb	8 ft.lb	9 ft.lb
0	0	0.138	0.277	0.415	0.553	0.691	0.830	0.968	1.106	1.245
10	1.383	1.521	1.660	1.798	1.936	2.074	2.212	2.351	2.489	2.628
20	2.766	2.904	3.043	3.181	3.319	3.457	3.596	3.734	3.872	4.011
30	4.149	4.287	4.426	4.564	4.702	4.840	4.979	5.117	5.255	5.394
40	5.532	5.670	5.809	5.947	6.085	6.223	6.362	6.500	6.638	6.777
50	6.915	7.053	7.191	7.330	7.468	7.606	7.745	7.883	8.021	8.159
60	8.298	8.436	8.574	8.713	8.851	8.989	9.128	9.266	9.404	9.543
70	9.681	9.819	9.957	10.09	10.23	10.37	10.51	10.65	10.79	10.92
80	11.06	11.20	11.34	11.48	11.62	11.75	11.89	12.03	12.17	12.31
90	12.45	12.59	12.73	12.86	13.00	13.14	13.28	13.42	13.55	13.69
100	13.83								ft lb x 0.1383 = kg·m	

## lbf-in to N·m

in.lb	0 in.lb	1 in.lb	2 in.lb	3 in.lb	4 in.lb	5 in.lb	6 in.lb	7 in.lb	8 in.lb	9 in.lb
0	0	0.113	0.226	0.339	0.452	0.565	0.678	0.791	0.904	1.02
10	1.13	1.24	1.36	1.47	1.58	1.70	1.81	1.92	2.03	2.15
20	2.26	2.37	2.49	2.60	2.71	2.83	2.94	3.05	3.16	3.28
30	3.39	3.50	3.62	3.73	3.84	3.96	4.07	4.18	4.29	4.41
40	4.52	4.63	4.75	4.86	4.97	5.09	5.20	5.31	5.42	5.54
50	5.65	5.76	5.88	5.99	6.10	6.22	6.33	6.44	6.55	6.67
60	6.78	6.89	7.01	7.12	7.23	7.35	7.46	7.57	7.68	7.80
70	7.91	8.02	8.14	8.25	8.36	8.48	8.59	8.70	8.81	8.93
80	9.04	9.15	9.27	9.38	9.49	9.61	9.72	9.83	9.94	10.06
90	10.17	10.28	10.40	10.51	10.62	10.74	10.85	10.96	11.07	11.19
100	11.30								in lb x 0.1130 = N·m	



## N·m to kg·m

N·m	0 N·m	1 N·m	2 N·m	3 N·m	4 N·m	5 N·m	6 N·m	7 N·m	8 N·m	9 N·m
0	0	0.102	0.204	0.306	0.408	0.510	0.632	0.714	0.816	0.918
10	1.020	1.122	1.224	1.326	1.428	1.530	2.651	1.733	1.835	1.937
20	2.039	2.141	2.243	2.345	2.447	2.549	3.671	2.753	2.855	2.957
30	3.059	3.161	3.263	3.365	3.467	3.569	4.691	3.773	3.875	3.977
40	4.079	4.181	4.283	4.385	4.487	4.589	5.710	4.793	4.895	4.997
50	5.099	5.200	5.302	5.404	5.506	5.608	6.730	5.812	5.914	6.016
60	6.118	6.220	6.322	6.424	6.526	6.628	7.750	6.832	6.934	7.036
70	7.138	7.240	7.342	7.444	7.546	7.648	8.769	7.852	7.954	8.056
80	8.158	8.260	8.362	8.464	8.566	8.668	9.789	8.871	8.973	9.075
90	9.177	9.279	9.381	9.483	9.585	9.687	13.28	9.891	9.993	10.095
100	10.197								N m x 0.10197 = m kg (ó m kp)	

## N·m to lbf-in

N·m	0 N·m	1 N·m	2 N·m	3 N·m	4 N·m	5 N·m	6 N·m	7 N·m	8 N·m	9 N·m
0	0	8.85	17.70	26.55	35.40	44.25	53.10	61.95	70.81	79.66
10	88.51	97.36	106.21	115.06	123.91	132.76	141.61	150.46	159.31	168.16
20	177.01	185.86	194.72	203.57	212.42	221.27	230.12	238.98	247.82	256.67
30	265.52	274.38	283.22	292.07	300.92	309.77	318.62	327.48	336.33	345.18
40	354.03	362.88	371.73	380.58	389.43	398.28	407.13	415.98	424.83	433.68
50	442.53	451.38	460.24	469.09	477.94	486.79	495.64	504.49	513.34	522.19
60	531.04	539.89	548.74	557.59	566.44	575.30	584.15	593.00	601.85	610.70
70	619.55	628.40	637.25	646.10	654.95	663.80	672.65	681.50	690.35	699.20

# RECOMMENDED TIGHTENING TORQUE

	Coarse Pitch			Resistant area	Friction coefficient	PROPERTY CLASS											
						4.8		5.8		6.8		8.8		10.9		12.9	
						Pre-load N	Torque N-m	Pre-load N	Torque N-m	Pre-load N	Torque N-m	Pre-load N	Torque N-m	Pre-load N	Torque N-m	Pre-load N	Torque N-m
M2	040	4	1,5	2,07	0,10 0,14	448,0 449,5	0,15 0,19	610,6 561,9	0,19 0,23	732,7 674,3	0,23 0,28	976,9 899,0	0,31 0,37	1373,8 1264,3	0,43 0,52	1648,6 1517,1	0,52 0,63
M2,5	045	5	2	3,39	0,10 0,14	813,5 749,9	0,31 0,38	1016,9 937,4	0,39 0,48	1220,2 1124,9	0,47 0,58	1627,0 1499,8	0,63 0,77	2288,0 2109,1	0,88 1,08	2745,6 2531,0	1,06 1,30
M3	050	5,5	2,5	5,03	0,10 0,14	1219,9 1125,9	0,54 0,60	1524,9 1407,4	0,68 0,83	1829,9 1688,9	0,82 1,00	2439,9 2251,9	1,09 1,34	3431,0 3166,7	1,53 1,88	4117,2 3800,0	1,84 2,26
M3,5	060	6	-	6,78	0,10 0,14	1638,2 1511,3	0,84 1,03	2047,8 1889,2	1,05 1,28	2457,3 2267,0	1,26 1,54	3276,4 3022,6	1,68 2,05	4607,5 4250,6	2,36 2,89	5528,9 5100,7	2,84 3,47
M4	070	7	3	8,78	0,10 0,14	2115,4 1950,9	1,25 1,53	2644,3 2438,7	1,56 1,91	3173,1 2926,4	1,88 2,29	4230,8 3901,9	2,50 3,06	5949,6 5487,0	3,52 4,30	7139,5 6584,4	4,22 5,16
M5	080	8	4	14,20	0,10 0,14	3461,6 3196,8	2,46 3,02	4327,0 3996,0	3,08 3,78	5192,3 4795,2	3,70 4,53	6923,1 6393,7	4,93 6,04	9735,7 8991,1	6,93 8,50	11682,8 10789,3	8,32 10,20
M6	100	10	5	20,10	0,10 0,14	4874,7 4499,1	4,24 5,19	6093,4 5623,9	5,30 6,48	7312,1 6748,6	6,35 7,78	9749,4 8998,2	8,47 10,37	13710,1 12653,7	11,92 14,59	16452,2 15184,4	14,30 17,51
M7	100	11	-	28,90	0,10 0,14	7134,5 6599,6	6,97 8,60	8918,2 8249,5	8,71 10,76	10701,8 9899,4	10,45 12,90	14269,1 13199,2	13,94 17,21	20065,9 18561,4	19,60 24,20	24079,1 22273,6	23,52 29,04
M8	125	13	6	36,60	0,10 0,14	8947,1 8265,6	10,20 12,54	11183,9 10332,0	12,75 15,67	13420,7 12398,4	15,30 18,80	17894,2 16531,2	20,41 25,07	25163,7 23247,0	28,70 35,26	30196,5 27896,5	34,44 42,31
M10	150	16	8	58,00	0,10 0,14	14244,5 13167,4	20,11 24,76	17805,6 16459,2	25,14 30,95	21366,8 19751,1	30,16 37,14	28489,0 26334,8	40,22 49,52	40062,7 37033,3	56,56 69,64	48075,3 44439,9	67,87 83,56
M12	175	18	10	84,30	0,10 0,14	20766,6 19204,0	34,43 42,42	25958,3 24005,0	43,03 53,03	31149,9 28806,0	51,64 63,63	41533,2 38408,0	68,86 84,84	58406,1 54011,2	96,83 119,31	70087,3 64813,5	116,20 143,17
M14	200	21	12	115,00	0,10 0,14	28389,9 26261,2	54,77 67,56	35487,4 32826,5	68,46 84,45	42584,9 39391,8	82,15 101,34	56779,8 52522,4	109,53 135,13	79846,6 73859,6	154,03 190,02	95816,0 88631,5	184,84 228,03
M16	200	24	14	157,00	0,10 0,14	39242,1 36364,2	85,14 105,80	49052,7 45455,3	106,43 132,26	58863,2 54546,3	127,72 158,71	78484,3 72728,5	170,29 211,61	110368,5 102274,4	239,47 297,58	132442,2 122729,3	287,36 357,09
M18	250	27	14	192,00	0,10 0,14	47533,0 43986,1	117,48 145,16	59416,3 54982,7	146,85 181,45	71299,6 65979,2	176,22 217,74	95066,1 87972,3	234,96 290,32	33686,7 123711,0	330,41 402,26	160424,1 148453,2	396,49 489,92
M20	250	30	17	245,00	0,10 0,14	61238,0 56747,1	166,08 206,39	76547,5 70933,9	207,61 257,98	91857,0 85120,6	249,13 309,58	122476,0 113494,2	332,17 412,78	172231,9 159601,2	467,11 580,47	206678,2 191521,5	560,54 696,56
M22	250	34	17	303,00	0,10 0,14	76305,2 70791,9	227,22 283,79	95381,5 88489,8	284,02 354,74	114457,8 106187,8	340,82 425,69	152610,4 141583,7	454,43 567,58	214608,3 199102,1	639,05 798,16	257530,0 238922,5	766,85 957,80
M24	300	36	19	353,00	0,10 0,14	88232,4 81761,8	287,16 356,84	110290,5 102202,2	358,94 446,05	132348,6 122642,7	430,73 535,26	176646,9 163523,6	574,31 713,68	248153,7 229955,1	807,63 1003,61	297784,4 275946,1	969,15 1204,33
M27	300	41	19	459,00	0,10 0,14	115778,8 107441,5	420,04 525,08	144723,5 134301,9	525,05 656,35	173668,2 161162,2	630,06 787,62	231557,6 214883,0	840,08 1050,16	325627,9 302179,2	1181,36 1476,79	390753,4 362615,0	1417,63 1772,15
M30	350	46	22	561,00	0,10 0,14	140999,5 130770,6	572,83 714,49	176249,4 163463,3	716,03 893,11	211499,3 196155,9	859,24 1071,73	281999,0 261541,2	1145,65 1428,97	396561,1 367792,3	1611,08 2009,49	475873,4 441350,8	1933,29 2411,39
M33	350	50	22	694,00	0,10 0,14	175618,1 163058,0	774,65 970,43	219522,6 203822,5	968,32 1213,03	263427,1 244587,0	1161,98 1455,64	351236,2 326115,9	1549,31 1940,86	493925,8 458600,5	2178,72 2729,33	592771,0 550320,6	2614,46 3275,19
M36	400	55	24	817,00	0,10 0,14	206081,7 191241,8	998,60 1248,41	257602,2 239052,3	1248,25 1560,51	309122,6 286862,7	1497,89 1872,61	412163,5 382483,6	1997,19 2496,81	579604,8 537867,6	2808,55 3511,14	695525,8 645441,1	3370,26 4213,37
M39	400	60	27	976,00	0,10 0,14	247520,0 229902,6	1291,81 1620,96	309400,0 287378,3	1614,77 2026,20	371279,9 344853,9	1937,72 2431,44	495039,9 459805,2	2583,63 3241,92	696149,8 646601,0	3633,23 4558,96	835379,8 775921,3	4359,88 5470,75
M42	450	65	-	1120,00	0,10 0,14	283225,0 262939,0	1601,25 2005,46	354031,2 328673,8	2001,57 2506,83	424837,4 394408,5	2401,88 3008,20	566449,9 525878,0	3202,51 4010,93	796570,1 739516,0	4503,53 5640,37	955884,2 887419,2	5404,23 6768,44
M45	450	70	32	1310,00	0,10 0,14	332751,5 309151,8	2005,51 2519,55	415939,4 386439,7	2506,89 3149,43	499127,3 463727,7	3008,26 3779,32	665503,0 618303,6	4011,02 5039,09	935863,6 869489,3	5640,50 7086,23	1123036,0 1043387,0	6768,60 8503,47
M48	500	75	-	1470,00	0,10 0,14	372429,3 345862,9	2406,51 3018,11	465536,6 432328,7	3008,14 3772,64	558644,0 518794,4	3609,77 4527,17	744858,6 691725,8	4813,03 6036,23	1047457,0 972739,4	6768,32 8488,45	1256949,0 1167287,0	8121,98 10186,14
M52	500	80	36	1760,00	0,10 0,14	448108,9 416499,0	3099,96 3900,52	560136,1 520623,8	3874,95 4875,65	672163,4 624748,5	4649,93 5850,78	896217,8 832998,0	6199,91 7801,04	1260306,0 1171404,0	8718,63 10970,21	1512368,0 1405684,0	10462,36 13164,25
M56	550	85	41	2030,00	0,10 0,14	516202,9 479683,4	3838,14 4824,40	645253,6 599604,2	4797,68 6030,50	774304,4 719525,1	5757,21 7236,60	1032406,0 959366,8	7676,29 9648,80	1451821,0 1349110,0	10794,78 13568,63	1742185,0 1618931,0	12953,73 16282,36
M60	550	90	-	2360,00	0,10 0,14	602498,5 560267,5	4754,64 5992,71	753123,1 700334,4	5943,30 7490,88	903747,8 840401,2	7131,96 8989,06	1204997,0 1120535,0	9509,28 11985,42	1694527,0 1575752,0	13372,43 16854,49	2033432,0 1890903,0	16046,91 20225,39
M64	600	95	46	2680,00	0,10 0,14	683339,5 635299,9	5746,17 7235,13	854174,4 794124,9	7182,71 9043,92	1025009,0 952949,8	8619,25 10852,70	1366679,0 1270600,0	11492,34 14470,27	1921892,0 1786781,0	16161,10 20348,82	2306271,0 2144137,0	19393,32 24418,58
M68	600	100	-	3060,00	0,10 0,14	782799,9 728201,8	6939,64 8758,24	978499,8 910252,2	8674,55 10947,80	1174200,0 1092303,0	10409,46 13137,36	1565600,0 1456404,0	13879,28 17516,48	2201625,0 2048068,0	19517,74 24632,55	2641950,0 2457681,0	23421,29 29559,06



# AFTER-SALES SERVICE

TORQUE PERFORMANCE TESTS, REPAIRS AND ADJUSTMENTS

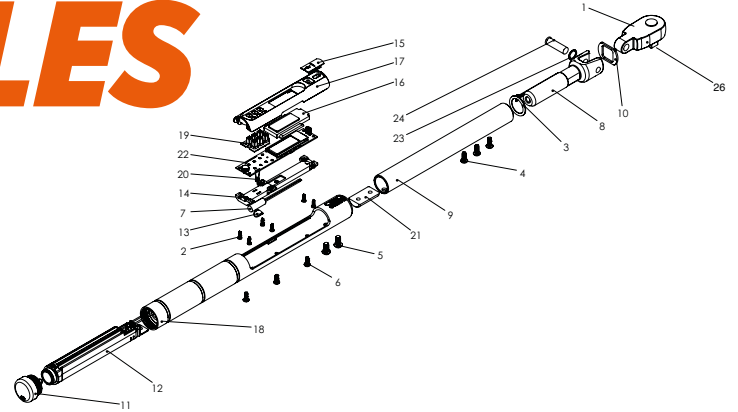

## AGILITY AND EFFICIENCY IN SERVICE

With a network of more than 20 torque repair facilities, and internal support with three repair centres in France, Holland and Spain

### From giving technical advice to repairing and calibrating torque tools

Our three internal repair centres offer reparation and adjustment for the Bahco torque wrenches family. With each repaired and adjusted torque wrench a declaration of conformance is included in accordance with ISO 6789-1:2017. Our declarations of conformance are traceable by calibration equipment calibrated by official laboratories recognised by ILAC (International Laboratory Accreditation Cooperation)

## SPECIFIC SERVICE MANUALS AND TRAINING MATERIAL

All our tools have specific technical documentation available to the Bahco partners and distributors:

- Exploded views.
- Service manuals with the disassembly-assembly, repair tips and tricks and guides for the torque deviation adjustment.
- Video guides with all the service processes.
- Self-training material.
- Troubleshooting guides

## SPARE PARTS AND REPAIR KITS AVAILABILITY

Offering original and precise-fitting spare parts for all our products and also specific repair kits, making the repairs and service easy and accessible to everybody



A dedicated YouTube channel containing short videos about how to maintain or repair your tools.

Check it out:  
<http://www.bahco.com/en/after-sales-service/>

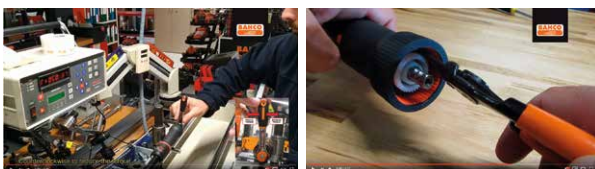

# FEATURE ICONS & SYMBOLS



Supplied in portable blow mould cases



In square semi-transparent hanging tubes



Bahco Connect App available for Windows 10, iOS and Android at the different stores.



Bluetooth® real time connectivity to PC or tablet



USB icon for wrench-PC data transfer



Digital torque reading wrench to know the torque/angle being applied at every moment



Dial torque reading wrench to know the torque being applied at every moment



Dual scale



Accuracy icon in clockwise direction



Accuracy icon in anticlockwise direction



Gives a click or beep warning to stop applying torque



Gives a click or vibration warning to stop applying torque



Visual feedback to operator



Break-back wrench with wider angle; longer time to stop after reaching target torque avoiding over-torque



Fixed pear reversible ratchet



Fixed round reversible ratchet



Fixed push-through ratchet head



Fixed square drive



Rectangular type interchangeable head



Round spigot type interchangeable head



Female hexagonal drive



Male Torx® tip



Male Torx Plus® tip

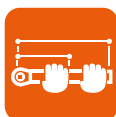

Free-hand point or non-length-dependent feature



Colour caps delivered along with the tool to easily identify the tool you need for the job at hand



ESD safe



Certificate to indicate declaration of conformity



CE declaration



Non sparking certified material



Dropped Objects Prevention Scheme compliant tools for use at height





**USE OUR PRODUCT FINDER TO SELECT THE RIGHT TORQUE WRENCH FOR THE JOB AT HAND.**

Our many years of knowledge and experience have led to a new range of Torque Solutions. Bahco offers you one of the largest selections of torque tools available, providing the durability, reliability and accuracy you need to turn and tighten fasteners to the right specification.

Discover the Bahco Torque Tool Finder! A user-friendly tool selection solution designed with Bahco end-users in mind. With an app-like interface and a customer-centric approach, the Torque Tool Finder simplifies the process of choosing the right product.

Accessible directly from bahco.com, this tool is a valuable resource that guides you through any uncertainties, ensuring you select the perfect torque tool for your needs. It is ready to address the most demanding requirements, including data storage and traceability, accessibility issues, special working environments, and ergonomics.



TORCAT-ENG-23

